

**JC
VALVES**
The quality option



**GATE, GLOBE
& CHECK VALVES**

C (open app.)

B (app.)

(ddb) B

A



| INDEX |

2

JC VALVES

The company

4

GATE VALVES

BOLTED BONNET

from Class 150 up to Class 2500
from 2" up to 36"

PRESSURE SEAL

from Class 900 up to Class 2500
from 2" up to 20"

16

GLOBE VALVES

BOLTED BONNET

from Class 150 up to Class 2500
from 2" up to 16"

PRESSURE SEAL

from Class 900 up to Class 2500
from 2" up to 16"

28

CHECK VALVES

BOLTED COVER

from Class 150 up to Class 2500
from 2" up to 36"

PRESSURE SEAL

from Class 900 up to Class 2500
from 2" up to 16"

40

TECHNICAL FEATURES



The quality option



"We make valves since 1968"

» JC World Wide

JC Valves provides world wide coverage thanks to the strategic locations of its factories and offices:

JC Fábrica de Válvulas S.A., established in 1968, is a multinational company specialised in the manufacture and sale of high quality industrial valves.

The expertise and know how acquired over the years coupled with the continued investments in the design of valves, has made JC a world renowned company in the field of valve applications.



» Market sectors

JC develops and designs valves for all applications, but the main focus is in Oil & Gas, Chemical, Petrochemical, Pulp & Paper and Energy sectors.



Oil



Chemical



Gas



Pulp & Paper



Petrochemical



Energy





» Quality assurance

JC Valves are designed and produced to meet the major international standards and we take great care and put a lot of emphasis on QUALITY, which provides our customers with a total guarantee and trouble free operation of their process. And in addition, we take great care to make our facilities and our products Environment friendly.

» Global services

JC Fábrica de Válvulas S.A. offers its customers a world wide service, from technical advice to choose the right valve up to the design and manufacture of custom built valves to meet special service requirements.

Our R+D department is always ready to find solutions for severe applications and our global distribution network offers quick availability of JC valves and an efficient after sales service.

GLOBAL SERVICE

TECHNICAL SUPPORT



DESIGN



MANUFACTURE



WORLD WIDE DISTRIBUTION



AFTER-SALES SERVICE



JC Quality Assurance System

- » ISO 9001 : 2000 certified by BVQI
- » API Q1 certified by the AMERICAN PETROLEUM INSTITUTE
- » PED 97 / 23 / EC certified by BVQI

Manufacturing Program

- » API 6D certified by the AMERICAN PETROLEUM INSTITUTE
- » CE Marking (Module H, Category III) in accordance with PED 97 / 23 / EC certified by BVQI
- » Fire Safe ISO 10947 : 2004
- » API 607 3rd., 4th. and 5th. Edition
- » BS 6755 Part 2 certified by Lloyd's Register and SGS
- » GOST "R" certified for Russian market
- » SIL 3 (Safety integrity level)
- » Atex

Environmental Certifications

- » ISO 14001 : 2004 certified by BVQI
- » ISO-EN 15848-1 certified by SGS



| GATE, GLOBE & CHECK VALVES |

GATE VALVES

2" - 36" | Class 150 - Class 2500



Gate valves serve as efficient on-off valves with flow in either direction. In such a design, a wedge slides across a general passageway in order to control fluid flow (like a sliding gate - hence, the name). One of the most significant characteristics of this type of valves is its straight-through, unobstructed passageway when set in the "full open" position. This is made possible by the wedge lifting entirely out of the passageway. As a result, gate valves are characterized by a minimum of turbulence and pressure drop in operation.

While gate valves are good for applications requiring these two factors, they are not recommended for installations in which throttling would be a function. They are designed for on/off service.

BILL OF MATERIALS		TRIM 8	TRIM 2	TRIM 8	TRIM 10
Item	Description	Carbon Steel	Carbon Steel (Low Temp.)	Alloy Steel	Stainless Steel
1	Body	A 216 Gr. WCB	A 352 Gr. LCB	A 217 Gr. C5	A 351 Gr. CF8M
2	Bonnet	A 216 Gr. WCB	A 352 Gr. LCB	A 217 Gr. C5	A 351 Gr. CF8M
3	Wedge	A 216 Gr. WCB + ER410	A 352 Gr. LCB + ER308	A 217 Gr. C5 + ER410	A 351 Gr. CF8M
4	Yoke	A 216 Gr. WCB	A 352 Gr. LCB	A 217 Gr. C5	A 351 Gr. CF8M
5	Stem	A 182 Gr. F6a	A 182 Graph. F304	A 182 Gr. F6a	A 182 Gr. F316
6	Seat Ring	A 105 + Stellite	A 182 Gr. F304	A 182 Gr. F6a + Stellite	----
7	Stem Nut	B 148 / A 439 Gr. D2	B 148 / A 439 Gr. D2	B 148 / A 439 Gr. D2	B 148 / A 439 Gr. D2
8	Backseat	A182 Gr. F6a	A182 Gr. F304	A 182 Gr. F6a	----
9	Gland	A 105	A 105	A 182 Gr. F6a	A 182 Gr. F316
10	Gland Flange	A 105	A 105	A 105	A 182 Gr. F304
11	Stem Packing	Graphite	Graphite	Graphite	Graphite
12	Gasket (Class 150)	SS304 / Graphite	SS304 / Graphite	SS304 / Graphite	SS316 / Graphite
12	Gasket (Class 300)	Spw SS304 / Graphite	Spw SS304 / Graphite	Spw SS304 / Graphite	Spw SS316 / Graphite
12	Gasket (Class 600)	Spw SS304 / Graphite	Spw SS304 / Graphite	Spw SS304 / Graphite	Spw SS316 / Graphite
12	Gasket (Class 900)	RJ SS304	RJ SS304	RJ SS304	RJ SS316
12	Gasket (Class 1500)	RJ SS304	RJ SS304	RJ SS304	RJ SS316
12	Gasket (Class 2500)	RJ SS304	RJ SS304	RJ SS304	RJ SS316
13	Bonnet Bolt & Nut	A 193 Gr. B7 / A 194 Gr. 2H	A320 Gr. L7 / A194 Gr. 7	A 193 Gr. B7 / A 194 Gr. 2H	A 193 Gr. B7 / A 194 Gr. 2H ⁽¹⁾
14	Eye Bolt & Nut	A 193 Gr. B7 / A 194 Gr. 2H	A 193 Gr. B7 / A 194 Gr. 2H	A 193 Gr. B7 / A 194 Gr. 2H	A 193 Gr. B7 / A 194 Gr. 2H
15	Handwheel	Carbon Steel	Carbon Steel	Carbon Steel	Carbon Steel

* Standard construction with trim 8, 2 and 10. Others constructions are available.
(1) Zinc coating.

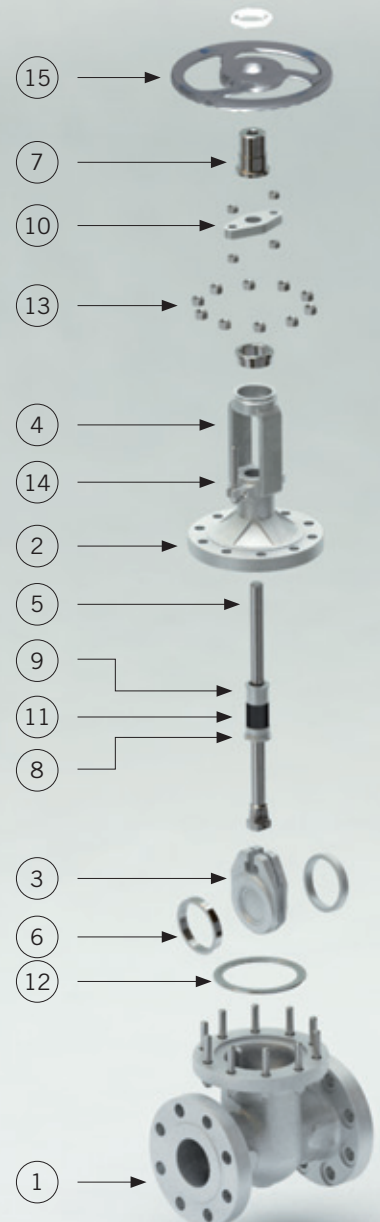

Body and Bonnet

Bodies and bonnets are high quality cast and afterwards precisely machined, directing the attention to prevent stress concentration.

The bodies of gate valves consist of a straight through port that guarantees minimal turbulence and resistance to flow. In both designs, bolted bonnet and pressure seal, the bodies consist of guide slots to accommodate the wedge during opening or closing of the valve.

Bonnets are made either of one piece only –the yoke then being an integral part of it– or have two pieces, depending on the size of the valve. This ensures the perfect alignment with the body what leads to an accurate opening and closing.

Backseat

All JC gate and globe valves have backseat threaded in the bonnet, or for the pressure seal valves, welded to the bonnet. Into pressure seal the hard facing is stellite 6 or equivalent.

Stem

The stems of JC gate valves are forged from one piece and ACME threaded, then mechanized and finally provided with a smooth finishing in order to minimize friction.

In gate valves, the union of stem and wedge shall be in T form, designed to prevent the stem disengaging itself from the wedge while being in service. This design includes a conical raised surface that presses the seat against the bonnet backseat in the fully open position.

Body and Bonnet Gaskets

The design of the body-bonnet/gaskets varies depending on the class of the valve.

Class 150 gate valves consist of a square joint in 2" and an oval one for all other sizes. Depending on the valve service it can be supplied flat-face gasket with graphite or PTFE.

Class 300 and 600 valves consist of a circular spiral wound gasket.

Class 900 and above gate valves consist of a ring type joint.

In pressure seal designs the sealing is achieved through a gasket that takes advantage of the internal pressure of the line. The material most commonly used is high-purity graphite being located between the body and the body retainer ring.

Flexible Wedge

All Jc gate valves 3" and above valves feature a flexible wedge unless otherwise specified by the customer. The flexible wedge shifts along the body of the valve during opening and closing, being held in position by a guide slot that minimizes the friction between body seat and wedge. This design is especially suited to compensate slight thermal deformations produced by the pipe or the valve itself safeguarding a better sealing between body and wedge seats.

STELLITE

DESIGN STANDARDS

Bolted Bonnet Gate Valve	API 600/ISO 10434 & ASME B16.34
Pressure Seal Gate Valve (Long & Short pattern)	ASME B16.34
API 603 Gate Valve	API 603
Through Conduit Gate Valve	API 6D
Cryogenic Gate	API 600 / BS 1873 & BS 6364
Face to Face / End to End Dimensions	ASME B16.10 / ISO 5752
End Flanged dimensions	ASME B16.5 / ISO 7005-1, ASME B16.47-A&B, MSS SP- 44 & API 605
Butt-weld End dimensions	ASME B16.25
Valve inspection & testing	API 600 / ISO 10434 & ISO 5208, EN 17266
Pressure - Temperature rating	ASME B16.34

TEST / INSPECTION METHODS & ACCEPTANCE CRITERIA

TEST / INSPECTION	METHOD	ACCEPTANCE CRITERIA
Visual Inspection		MSS SP-55
Marking		MSS SP-25 & ISO5208
Dimensional Inspection		Aplicable valve
Chemical Analysis	ASTM E350	Aplicable Standard
Mechanical Properties	ASTM A370	Aplicable Standard
Liquid Penetrant Inspection	ASTM A165	ASME B16.34
Magnetic Particle Inspection	ASTM E709	ASME B16.34
Radiographic Inspection	ASME B16.34	ASME B16.34
Ultrasonic Inspection	ASTM A388	ASME B16.34
Pressure Testing	API 598 / ISO 5208	API 598 / ISO 5208

API 600 / BS1414 BOLTED BONNET

Class 150

VC150BB

Sizes 2" to 36"

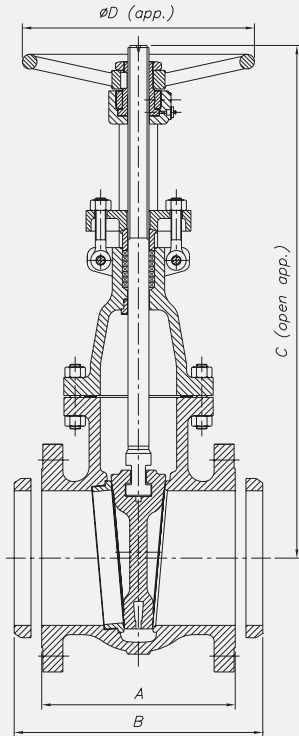

Carbon steel and alloy steel construction

Stainless steel construction

TRIM

API 600 TRIM N°	Nominal TRIM	Stem / Backseat	Seating Surface Body / Wedge
1	F6	13Cr	13Cr
2	304	18Cr-8Ni	18Cr-8Ni
3	F310	25Cr-20Ni	25Cr-20Ni
4	Hard F6	13Cr	Hard 13Cr
5	Hardfaced	13Cr	Co-Cr A
5A	Hardfaced	13Cr	Ni-Cr
6	F6 and Cu-Ni	13Cr	13Cr and Cu-Ni
7	F6 and Hard F6	13Cr	13Cr and Hard 13Cr
8	F6 and Hardfaced	13Cr	13Cr and Co-Cr A
8A	F6 and Hardfaced	13Cr	13Cr and Ni-Cr
9	Monel	Ni-Cu Alloy	Ni-Cu Alloy
10	316	18Cr-8Ni-Mo	18Cr-8Ni-Mo
11	Monel and Hardfaced	Ni-Cu Alloy	Ni-Cu Alloy and Trim 5 or 5A
12	316 and Hardfaced	18Cr-8Ni-Mo	18Cr-8Ni-Mo and Trim 5 or 5A
13	Alloy 20	19Cr-29Ni	19Cr-29Ni
14	Alloy 20 and Hardfaced	19Cr-29Ni	19Cr-29Ni and Trim 5 or 5A
15	Hardfaced	18Cr-8Ni	Co-CrR A
16	Hardfaced	18Cr-8Ni-Mo	Co-CrR A
17	Hardfaced	18Cr-10Ni-Cb	Co-CrR A
18	Hardfaced	19Cr-29Ni	Co-CrR A

HF: Hard Facing using CoCr welding alloy (Stellite)

Materials

ACC. / ASME B16.34
 DI, WCB, WCC, WC1, WC6, WC9, C5, C12, LCB, LCC, CF8, CF8C, CF8M, CF3, CF3M,
 DUPLEX, SUPERDUPLEX, EXOTIC MATERIALS.

General dimensions

DN	A	B	C	ØD	WEIGHT (App.) ^(*)
50 (2")	178	216	386	200	17
65 (2½")	190	241	435	200	27
80 (3")	203	282,5	483	250	33
100 (4")	229	305	587	250	48
125 (5")	254	381	673	300	65
150 (6")	267	403	767	300	78
200 (8")	292	419	955	350	120
250 (10")	330	457	1146	450	176
300 (12")	356	502	1328	500	260
350 (14")	381	572	1519	460 ^(*)	380 ^(*)
400 (16")	406	610	1721	460 ^(*)	530 ^(*)
450 (18")	432	660	1900	460 ^(*)	620 ^(*)
500 (20")	457	711	2116	610 ^(*)	810 ^(*)
550 (22")	483	762	2315	610 ^(*)	1050 ^(*)
600 (24")	508	813	2480	610 ^(*)	1150 ^(*)
650 (26")	559	-	2700	610 ^(*)	1380 ^(*)
700 (28")	610	-	2975	610 ^(*)	1980 ^(*)
750 (30")	610	-	3102	610 ^(*)	2200 ^(*)
900 (36")	711	-	3668	710 ^(*)	2800 ^(*)

^(*) With Gear Operator.^(**) With flanges.

Dimensions in mm and weight in kg.

Weights and dimensions can be changed without notice.

Bigger sizes available under customer request.

API 600 / BS1414 BOLTED BONNET

Class 300

VC300BB

Sizes 2" to 24"

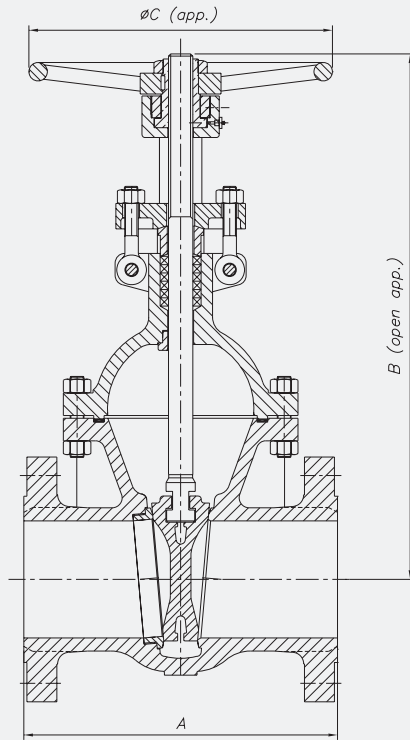

Carbon steel and alloy steel construction

Stainless steel construction

TRIM

API 600 TRIM N°	Nominal TRIM	Stem / Backseat	Seating Surface Body / Wedge
1	F6	13Cr	13Cr
2	304	18Cr-8Ni	18Cr-8Ni
3	F310	25Cr-20Ni	25Cr-20Ni
4	Hard F6	13Cr	Hard 13Cr
5	Hardfaced	13Cr	Co-Cr A
5A	Hardfaced	13Cr	Ni-Cr
6	F6 and Cu-Ni	13Cr	13Cr and Cu-Ni
7	F6 and Hard F6	13Cr	13Cr and Hard 13Cr
8	F6 and Hardfaced	13Cr	13Cr and Co-Cr A
8A	F6 and Hardfaced	13Cr	13Cr and Ni-Cr
9	Monel	Ni-Cu Alloy	Ni-Cu Alloy
10	316	18Cr-8Ni-Mo	18Cr-8Ni-Mo
11	Monel and Hardfaced	Ni-Cu Alloy	Ni-Cu Alloy and Trim 5 or 5A
12	316 and Hardfaced	18Cr-8Ni-Mo	18Cr-8Ni-Mo and Trim 5 or 5A
13	Alloy 20	19Cr-29Ni	19Cr-29Ni
14	Alloy 20 and Hardfaced	19Cr-29Ni	19Cr-29Ni and Trim 5 or 5A
15	Hardfaced	18Cr-8Ni	Co-Cr A
16	Hardfaced	18Cr-8Ni-Mo	Co-Cr A
17	Hardfaced	18Cr-10Ni-Cb	Co-Cr A
18	Hardfaced	19Cr-29Ni	Co-Cr A

HF: Hard Facing using CoCr welding alloy (Stellite)

Materials

ACC. / ASME B16.34
 DI, WCB, WCC, WC1, WC6, WC9, C5, C12, LCB, LCC, CF8, CF8C, CF8M, CF3, CF3M,
 DUPLEX, SUPERDUPLEX, EXOTIC MATERIALS.

General dimensions

DN	A (RF / BW)	B	ØC	WEIGHT (App.)
50 (2")	216	417	200	24
65 (2½")	241	460	250	35
80 (3")	282,5	526	250	49
100 (4")	305	650	250	69
125 (5")	381	694	300	92
150 (6")	403	824	350	130
200 (8")	419	987	450	208
250 (10")	457	1192	500	333
300 (12")	502	1431	560	536
350 (14")	762	1559	460 (*)	699 (*)
400 (16")	838	1758	460 (*)	1010 (*)
450 (18")	914	1942	610 (*)	1205 (*)
500 (20")	991	2145	610 (*)	1720 (*)
550 (22")	1092	2340	610 (*)	1920 (*)
600 (24")	1143	2526	610 (*)	2580 (*)

(*) With Gear Operator.

Dimensions in mm and weight in kg.
 Weights and dimensions can be changed without notice.
 Bigger sizes available under customer request.

API 600 / BS1414 BOLTED BONNET

Class 600

VC600BB

Sizes 2" to 24"

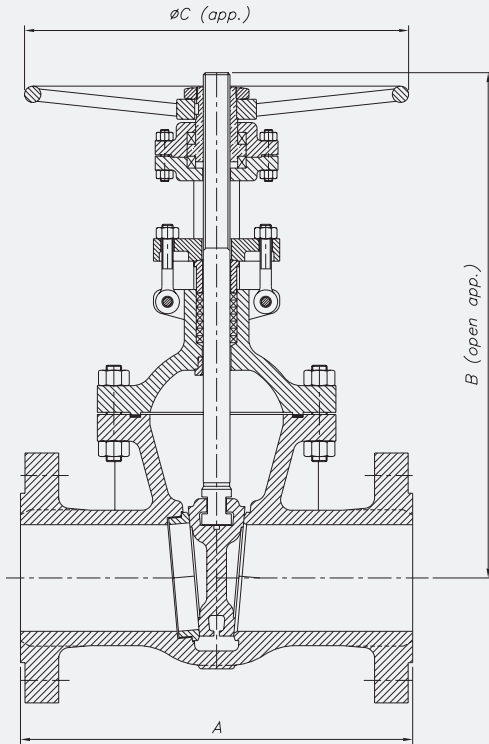

Carbon and alloy steel construction

Stainless steel construction

TRIM

API 600 TRIM N°	Nominal TRIM	Stem / Backseat	Seating Surface Body / Wedge
1	F6	13Cr	13Cr
2	304	18Cr-8Ni	18Cr-8Ni
3	F310	25Cr-20Ni	25Cr-20Ni
4	Hard F6	13Cr	Hard 13Cr
5	Hardfaced	13Cr	Co-Cr A
5A	Hardfaced	13Cr	Ni-Cr
6	F6 and Cu-Ni	13Cr	13Cr and Cu-Ni
7	F6 and Hard F6	13Cr	13Cr and Hard 13Cr
8	F6 and Hardfaced	13Cr	13Cr and Co-Cr A
8A	F6 and Hardfaced	13Cr	13Cr and Ni-Cr
9	Monel	Ni-Cu Alloy	Ni-Cu Alloy
10	316	18Cr-8Ni-Mo	18Cr-8Ni-Mo
11	Monel and Hardfaced	Ni-Cu Alloy	Ni-Cu Alloy and Trim 5 or 5A
12	316 and Hardfaced	18Cr-8Ni-Mo	18Cr-8Ni-Mo and Trim 5 or 5A
13	Alloy 20	19Cr-29Ni	19Cr-29Ni
14	Alloy 20 and Hardfaced	19Cr-29Ni	19Cr-29Ni and Trim 5 or 5A
15	Hardfaced	18Cr-8Ni	Co-CrR A
16	Hardfaced	18Cr-8Ni-Mo	Co-CrR A
17	Hardfaced	18Cr-10Ni-Cb	Co-CrR A
18	Hardfaced	19Cr-29Ni	Co-CrR A

HF: Hard Facing using CoCr welding alloy (Stellite)

Materials

ACC. / ASME B16.34
 DI, WCB, WCC, WC1, WC6, WC9, C5, C12, LCB, LCC, CF8, CF8C, CF8M, CF3, CF3M,
 DUPLEX, SUPERDUPLEX, EXOTIC MATERIALS.

General dimensions

DN	A (RF/BW)	B	ØC	WEIGHT (App.)
50 (2")	292	427	250	33
65 (2½")	330	473	250	58
80 (3")	356	538	300	63
100 (4")	432	657	350	131
125 (5")	508	770	400	182
150 (6")	559	872	500	253
200 (8")	660	1101	560	413
250 (10")	787	1279	720	623
300 (12")	838	1486	610 (*)	784 (*)
350 (14")	889	1643	610 (*)	1288 (*)
400 (16")	991	1798	610 (*)	1820 (*)
450 (18")	1092	2101	610 (*)	2150 (*)
500 (20")	1194	2259	710 (*)	2540 (*)
550 (22")	1295	2405	760 (*)	2800 (*)
600 (24")	1397	2545	760 (*)	3350 (*)

(*) With Gear Operator.
 Dimensions in mm and weight in kg.
 Weights and dimensions can be changed without notice.
 Bigger sizes available under customer request.

API 600 / BS1414 BOLTED BONNET

Class 900

VC900BB

Sizes 2" to 20"

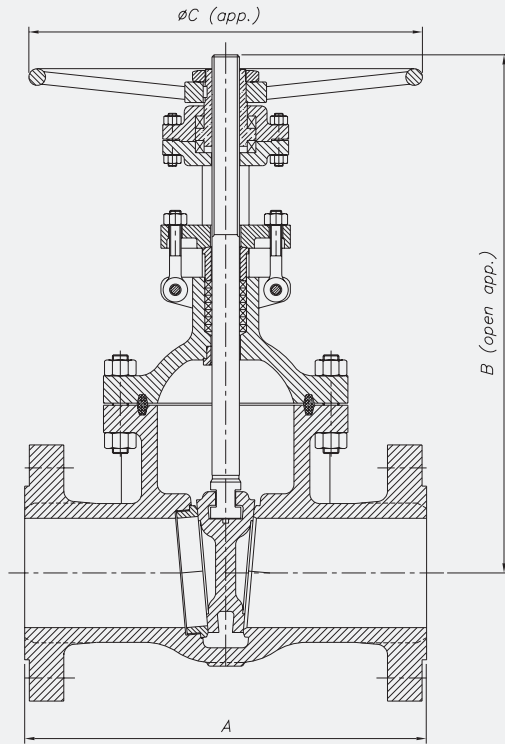

Carbon and alloy steel construction

Stainless steel construction

TRIM

API 600 TRIM N°	Nominal TRIM	Stem / Backseat	Seating Surface Body / Wedge
1	F6	13Cr	13Cr
2	304	18Cr-8Ni	18Cr-8Ni
3	F310	25Cr-20Ni	25Cr-20Ni
4	Hard F6	13Cr	Hard 13Cr
5	Hardfaced	13Cr	Co-Cr A
5A	Hardfaced	13Cr	Ni-Cr
6	F6 and Cu-Ni	13Cr	13Cr and Cu-Ni
7	F6 and Hard F6	13Cr	13Cr and Hard 13Cr
8	F6 and Hardfaced	13Cr	13Cr and Co-Cr A
8A	F6 and Hardfaced	13Cr	13Cr and Ni-Cr
9	Monel	Ni-Cu Alloy	Ni-Cu Alloy
10	316	18Cr-8Ni-Mo	18Cr-8Ni-Mo
11	Monel and Hardfaced	Ni-Cu Alloy	Ni-Cu Alloy and Trim 5 or 5A
12	316 and Hardfaced	18Cr-8Ni-Mo	18Cr-8Ni-Mo and Trim 5 or 5A
13	Alloy 20	19Cr-29Ni	19Cr-29Ni
14	Alloy 20 and Hardfaced	19Cr-29Ni	19Cr-29Ni and Trim 5 or 5A
15	Hardfaced	18Cr-8Ni	Co-Cr A
16	Hardfaced	18Cr-8Ni-Mo	Co-Cr A
17	Hardfaced	18Cr-10Ni-Cb	Co-Cr A
18	Hardfaced	19Cr-29Ni	Co-Cr A

HF: Hard Facing using CoCr welding alloy (Stellite)

Materials

ACC. / ASME B16.34
 DI, WCB, WCC, WC1, WC6, WC9, C5, C12, LCB, LCC, CF8, CF8C, CF8M, CF3, CF3M,
 DUPLEX, SUPERDUPLEX, EXOTIC MATERIALS.

General dimensions

DN	A (RF/BW)	B	ØC	WEIGHT (App.)
50 (2")	368	547	300	90
65 (2½")	419	700	350	110
80 (3")	381	648	400	123
100 (4")	457	729	450	148
125 (5")	559	890	500	280
150 (6")	610	1041	560	420
200 (8")	737	1260	460 (*)	650 (*)
250 (10")	838	1590	610 (*)	1160 (*)
300 (12")	965	1795	610 (*)	1700 (*)
350 (14")	1029	2025	760 (*)	2300 (*)
400 (16")	1130	2170	760 (*)	2750 (*)
450 (18")	1219	2345	760 (*)	3120 (*)
500 (20")	1321	2610	760 (*)	3550 (*)

(*) With Gear Operator.

Dimensions in mm and weight in kg.

Weights and dimensions can be changed without notice.

Bigger sizes available under customer request.

API 600 / BS1414 BOLTED BONNET

Class 1500

VC1500BB

Sizes 2" to 16"

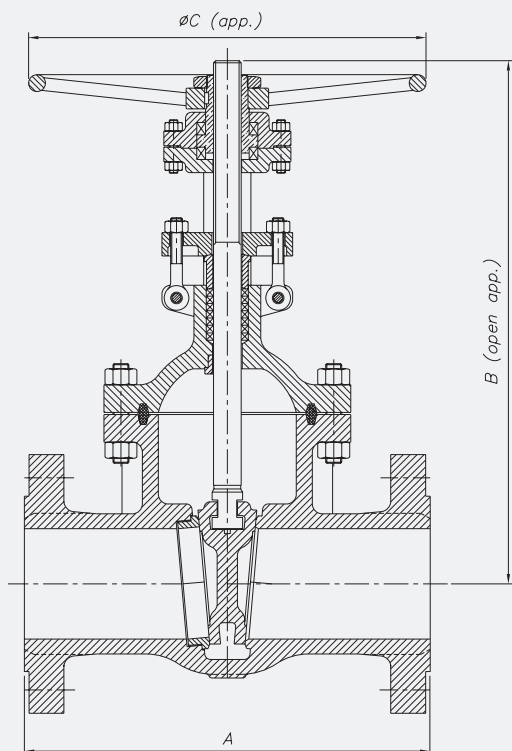

Carbon and alloy steel construction

Stainless steel construction

TRIM

API 600 TRIM N°	Nominal TRIM	Stem / Backseat	Seating Surface Body / Wedge
1	F6	13Cr	13Cr
2	304	18Cr-8Ni	18Cr-8Ni
3	F310	25Cr-20Ni	25Cr-20Ni
4	Hard F6	13Cr	Hard 13Cr
5	Hardfaced	13Cr	Co-Cr A
5A	Hardfaced	13Cr	Ni-Cr
6	F6 and Cu-Ni	13Cr	13Cr and Cu-Ni
7	F6 and Hard F6	13Cr	13Cr and Hard 13Cr
8	F6 and Hardfaced	13Cr	13Cr and Co-Cr A
8A	F6 and Hardfaced	13Cr	13Cr and Ni-Cr
9	Monel	Ni-Cu Alloy	Ni-Cu Alloy
10	316	18Cr-8Ni-Mo	18Cr-8Ni-Mo
11	Monel and Hardfaced	Ni-Cu Alloy	Ni-Cu Alloy and Trim 5 or 5A
12	316 and Hardfaced	18Cr-8Ni-Mo	18Cr-8Ni-Mo and Trim 5 or 5A
13	Alloy 20	19Cr-29Ni	19Cr-29Ni
14	Alloy 20 and Hardfaced	19Cr-29Ni	19Cr-29Ni and Trim 5 or 5A
15	Hardfaced	18Cr-8Ni	Co-CrR A
16	Hardfaced	18Cr-8Ni-Mo	Co-CrR A
17	Hardfaced	18Cr-10Ni-Cb	Co-CrR A
18	Hardfaced	19Cr-29Ni	Co-CrR A

HF: Hard Facing using CoCr welding alloy (Stellite)

Materials

ACC. / ASME B16.34

DI, WCB, WCC, WC1, WC6, WC9, C5, C12, LCB, LCC, CF8, CF8C, CF8M, CF3, CF3M, DUPLEX, SUPERDUPLEX, EXOTIC MATERIALS.

General dimensions

DN	A (RF/BW)	B	ØC	WEIGHT (App.)
50 (2")	368	574	350	117
65 (2½")	419	700	400	175
80 (3")	470	806	450	240
100 (4")	546	887	560	337
125 (5")	673	995	560	485
150 (6")	705	1079	305 (*)	680
200 (8")	832	1370	610 (*)	1228 (*)
250 (10")	991	1520	760 (*)	2218 (*)
300 (12")	1130	1651	760 (*)	3260 (*)
350 (14")	1257	1825	760 (*)	3990 (*)
400 (16")	1384	1995	760 (*)	5420 (*)

(*) With Gear Operator.

Dimensions in mm and weight in kg.

Weights and dimensions can be changed without notice.

Bigger sizes available under customer request.

API 600 / BS1414 BOLTED BONNET

Class 2500

VC2500BB

Sizes 2" to 14"

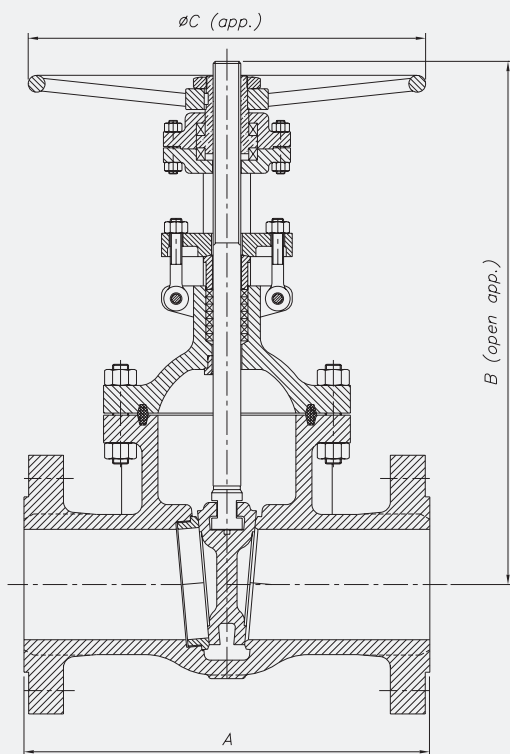

Carbon and alloy steel construction

Stainless steel construction

TRIM

API 600 TRIM N°	Nominal TRIM	Stem / Backseat	Seating Surface Body / Wedge
1	F6	13Cr	13Cr
2	304	18Cr-8Ni	18Cr-8Ni
3	F310	25Cr-20Ni	25Cr-20Ni
4	Hard F6	13Cr	Hard 13Cr
5	Hardfaced	13Cr	Co-Cr A
5A	Hardfaced	13Cr	Ni-Cr
6	F6 and Cu-Ni	13Cr	13Cr and Cu-Ni
7	F6 and Hard F6	13Cr	13Cr and Hard 13Cr
8	F6 and Hardfaced	13Cr	13Cr and Co-Cr A
8A	F6 and Hardfaced	13Cr	13Cr and Ni-Cr
9	Monel	Ni-Cu Alloy	Ni-Cu Alloy
10	316	18Cr-8Ni-Mo	18Cr-8Ni-Mo
11	Monel and Hardfaced	Ni-Cu Alloy	Ni-Cu Alloy and Trim 5 or 5A
12	316 and Hardfaced	18Cr-8Ni-Mo	18Cr-8Ni-Mo and Trim 5 or 5A
13	Alloy 20	19Cr-29Ni	19Cr-29Ni
14	Alloy 20 and Hardfaced	19Cr-29Ni	19Cr-29Ni and Trim 5 or 5A
15	Hardfaced	18Cr-8Ni	Co-Cr A
16	Hardfaced	18Cr-8Ni-Mo	Co-Cr A
17	Hardfaced	18Cr-10Ni-Cb	Co-Cr A
18	Hardfaced	19Cr-29Ni	Co-Cr A

HF: Hard Facing using CoCr welding alloy (Stellite)

Materials

ACC. / ASME B16.34
 DI, WCB, WCC, WC1, WC6, WC9, C5, C12, LCB, LCC, CF8, CF8C, CF8M, CF3, CF3M,
 DUPLEX, SUPERDUPLEX, EXOTIC MATERIALS.

General dimensions

DN	A (RF/BW)	B	ØC	WEIGHT (App.)
50 (2")	451	595	400	155
65 (2½")	508	675	450	215
80 (3")	578	750	560	285
100 (4")	673	805	610	405
125 (5")	794	1010	610	715
150 (6")	914	1200	460 (*)	1050 (*)
200 (8")	1022	1346	610 (*)	1700 (*)
250 (10")	1270	1500	760 (*)	2950 (*)
300 (12")	1422	1700	760 (*)	4120 (*)
350 (14")	1575	1950	760 (*)	5790 (*)

(*) With Gear Operator.

Dimensions in mm and weight in kg.

Weights and dimensions can be changed without notice.

Bigger sizes available under customer request.

| GATE, GLOBE, CHECK VALVES |

GATE VALVES

PRESSURE SEAL

2" - 20" | Class 900 - Class 2500

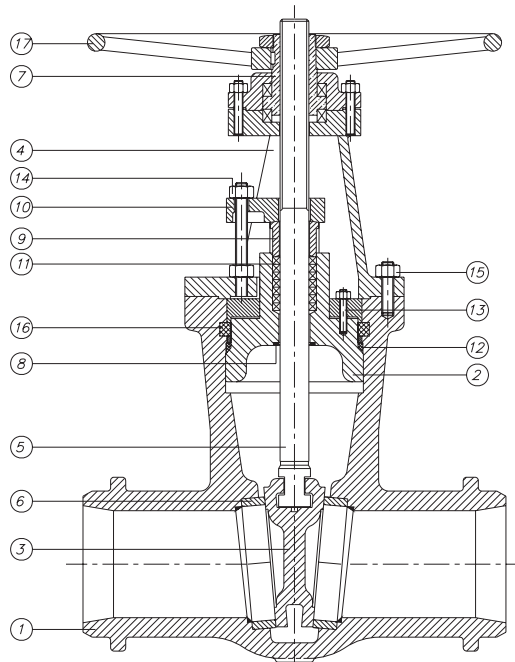

BILL OF MATERIALS		TRIM 8	TRIM 2	TRIM 8	TRIM 10
Item	Description	Carbon Steel	Carbon Steel (Low Temp.)	Alloy Steel	Stainless Steel
1	Body	A 216 Gr. WCB	A 352 Gr. LCB	A 217 Gr. C5	A 351 Gr. CF8M
2	Bonnet	A 216 Gr. WCB	A 352 Gr. LCB	A 217 Gr. C5	A 351 Gr. CF8M
3	Wedge	A 216 Gr. WCB + Stellite	A 352 Gr. LCB + Stellite	A 217 Gr. C5 + Stellite	A 351 Gr. CF8M + Stellite
4	Yoke	A 216 Gr. WCB	A 352 Gr. LCB	A 217 Gr. C5	A 351 Gr. CF8M
5	Stem	A 182 Gr. F6a	A 182 Gr. F304	A 182 Gr. F6a	A 182 Gr. F316
6	Seat Ring	A 105 + Stellite	A 182 Gr. F304 + Stellite	A 182 Gr. F6a + Stellite	A 182 Gr. F316 + Stellite
7	Stem Nut	B 148 / A 439 Gr. D2	B 148 / A 439 Gr. D2	B 148 / A 439 Gr. D2	B 148 / A 439 Gr. D2
8	Backseat	Stellite	Stellite	Stellite	Stellite
9	Gland	A 105	A 105	A 182 Gr. F6a	A 182 Gr. F316
10	Gland Flange	A 105	A 105	A 105	A 182 Gr. F304
11	Stem Packing	Graphite	Graphite	Graphite	Graphite
12	Gasket (Class 900)	Graphite or SS304L	Graphite or SS304L	Graphite or SS304L	Graphite or SS316L
12	Gasket (Class 1500)	Graphite or SS304L	Graphite or SS304L	Graphite or SS304L	Graphite or SS316L
12	Gasket (Class 2500)	Graphite or SS304L	Graphite or SS304L	Graphite or SS304L	Graphite or SS316L
13	Bonnet Bolt & Nut	A 193 Gr. B7 / A 194 Gr. 2H	A320 Gr. L7 / A194 Gr. 7	A 193 Gr. B7 / A 194 Gr. 2H	A 193 Gr. B7 / A 194 Gr. 2H ⁽¹⁾
14	Bolt & Nut	A 193 Gr. B7 / A 194 Gr. 2H	A 193 Gr. B7 / A 194 Gr. 2H	A 193 Gr. B7 / A 194 Gr. 2H	A 193 Gr. B7 / A 194 Gr. 2H
15	Yoke Bolt & Nut	A 193 Gr. B7 / A 194 Gr. 2H	A 193 Gr. B7 / A 194 Gr. 2H	A 193 Gr. B7 / A 194 Gr. 2H	A 193 Gr. B7 / A 194 Gr. 2H ⁽¹⁾
16	Segmental Ring	A 515 Gr. 70	A 182 Gr. F304	A 182 Gr. F304	A 182 Gr. F316
17	Handwheel	Carbon Steel	Carbon Steel	Carbon Steel	Carbon Steel

(1) Zinc coating.

ASME B16.34 PRESSURE SEAL

Class 900

VC900PS

Sizes 2" to 20"

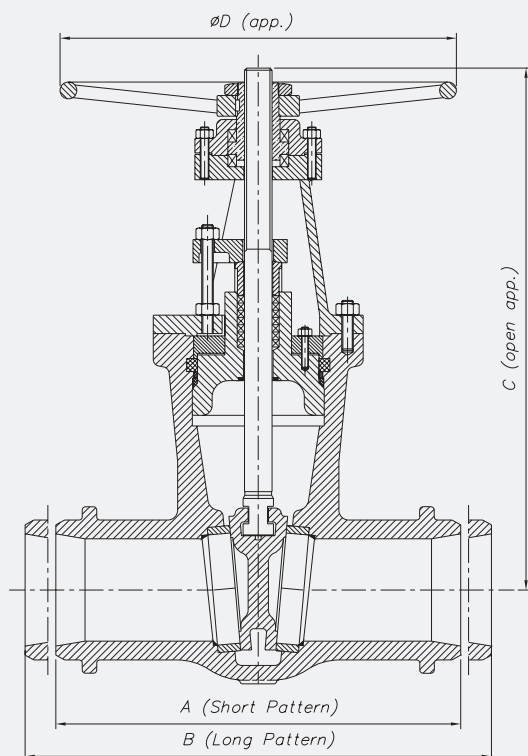

* Long pattern available with flanges.

TRIM

API 600 TRIM N°	Nominal TRIM	Stem / Backseat	Seating Surface Body / Wedge
1	F6	13Cr	13Cr
2	304	18Cr-8Ni	18Cr-8Ni
3	F310	25Cr-20Ni	25Cr-20Ni
4	Hard F6	13Cr	Hard 13Cr
5	Hardfaced	13Cr	Co-Cr A
5A	Hardfaced	13Cr	Ni-Cr
6	F6 and Cu-Ni	13Cr	13Cr and Cu-Ni
7	F6 and Hard F6	13Cr	13Cr and Hard 13Cr
8	F6 and Hardfaced	13Cr	13Cr and Co-Cr A
8A	F6 and Hardfaced	13Cr	13Cr and Ni-Cr
9	Monel	Ni-Cu Alloy	Ni-Cu Alloy
10	316	18Cr-8Ni-Mo	18Cr-8Ni-Mo
11	Monel and Hardfaced	Ni-Cu Alloy	Ni-Cu Alloy and Trim 5 or 5A
12	316 and Hardfaced	18Cr-8Ni-Mo	18Cr-8Ni-Mo and Trim 5 or 5A
13	Alloy 20	19Cr-29Ni	19Cr-29Ni
14	Alloy 20 and Hardfaced	19Cr-29Ni	19Cr-29Ni and Trim 5 or 5A
15	Hardfaced	18Cr-8Ni	Co-Cr A
16	Hardfaced	18Cr-8Ni-Mo	Co-Cr A
17	Hardfaced	18Cr-10Ni-Cb	Co-Cr A
18	Hardfaced	19Cr-29Ni	Co-Cr A

HF: Hard Facing using CoCr welding alloy (Stellite)

Materials

ACC. / ASME B16.34
 DI, WCB, WCC, WC1, WC6, WC9, C5, C12, LCB, LCC, CF8, CF8C, CF8M, CF3, CF3M,
 DUPLEX, SUPERDUPLEX, EXOTIC MATERIALS.

General dimensions

DN	A	B	C	ØD	WEIGHT (App.) ^(**)
50 (2")	216	368	570	250	55
65 (2½")	254	419	680	250	65
80 (3")	305	381	795	350	80
100 (4")	356	457	870	350	215
125 (5")	432	559	975	400	275
150 (6")	508	610	1070	460	320
200 (8")	660	737	1360	400 ^(*)	580 ^(*)
250 (10")	787	838	1505	400 ^(*)	890 ^(*)
300 (12")	914	965	1630	460 ^(*)	1105 ^(*)
350 (14")	991	1029	1795	500 ^(*)	1370 ^(*)
400 (16")	1092	1130	1945	610 ^(*)	2050 ^(*)
450 (18")	-	1219	2155	610 ^(*)	2780 ^(*)
500 (20")	-	1321	2305	710 ^(*)	3420 ^(*)

(*) With Gear Operator.

(**) BW ends, short pattern.

Dimensions in mm and weight in kg.

Weights and dimensions can be changed without notice.

Bigger sizes available under customer request.

ASME B16.34 PRESSURE SEAL

Class 1500

VC1500PS

Sizes 2" to 18"

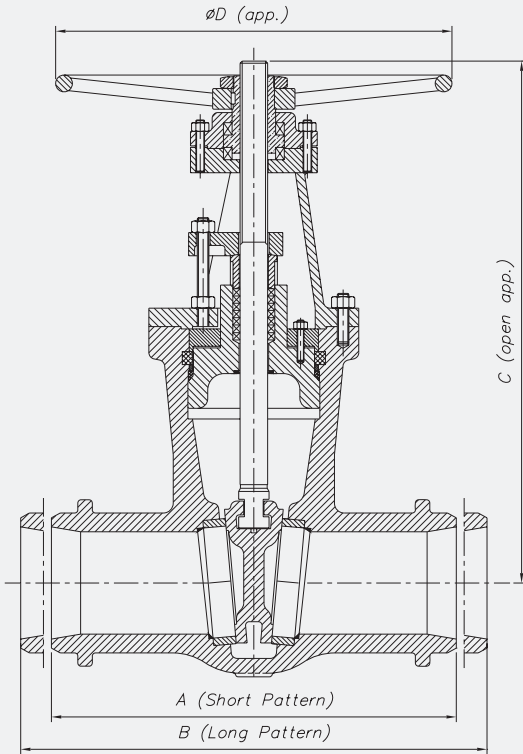

* Long pattern available with flanges.

TRIM

API 600 TRIM N°	Nominal TRIM	Stem / Backseat	Seating Surface Body / Wedge
1	F6	13Cr	13Cr
2	304	18Cr-8Ni	18Cr-8Ni
3	F310	25Cr-20Ni	25Cr-20Ni
4	Hard F6	13Cr	Hard 13Cr
5	Hardfaced	13Cr	Co-Cr A
5A	Hardfaced	13Cr	Ni-Cr
6	F6 and Cu-Ni	13Cr	13Cr and Cu-Ni
7	F6 and Hard F6	13Cr	13Cr and Hard 13Cr
8	F6 and Hardfaced	13Cr	13Cr and Co-Cr A
8A	F6 and Hardfaced	13Cr	13Cr and Ni-Cr
9	Monel	Ni-Cu Alloy	Ni-Cu Alloy
10	316	18Cr-8Ni-Mo	18Cr-8Ni-Mo
11	Monel and Hardfaced	Ni-Cu Alloy	Ni-Cu Alloy and Trim 5 or 5A
12	316 and Hardfaced	18Cr-8Ni-Mo	18Cr-8Ni-Mo and Trim 5 or 5A
13	Alloy 20	19Cr-29Ni	19Cr-29Ni
14	Alloy 20 and Hardfaced	19Cr-29Ni	19Cr-29Ni and Trim 5 or 5A
15	Hardfaced	18Cr-8Ni	Co-CrR A
16	Hardfaced	18Cr-8Ni-Mo	Co-CrR A
17	Hardfaced	18Cr-10Ni-Cb	Co-CrR A
18	Hardfaced	19Cr-29Ni	Co-CrR A

HF: Hard Facing using CoCr welding alloy (Stellite)

Materials

ACC. / ASME B16.34
 DI, WCB, WCC, WC1, WC6, WC9, C5, C12, LCB, LCC, CF8, CF8C, CF8M, CF3, CF3M,
 DUPLEX, SUPERDUPLEX, EXOTIC MATERIALS.

General dimensions

DN	A	B	C	$\varnothing D$	WEIGHT (App.) ^(*)
50 (2")	216	368	574	250	67
65 (2½")	254	419	700	350	95
80 (3")	305	470	806	350	119
100 (4")	406	546	887	400	280
125 (5")	483	673	990	460	370
150 (6")	559	705	1079	460 ^(*)	475 ^(*)
200 (8")	711	832	1370	710 ^(*)	855 ^(*)
250 (10")	863	991	1520	710 ^(*)	1222 ^(*)
300 (12")	991	1130	1650	710 ^(*)	1470 ^(*)
350 (14")	1067	1257	1820	710 ^(*)	1990 ^(*)
400 (16")	1194	1384	1990	760 ^(*)	2850 ^(*)
450 (18")	1346	1537	2180	760 ^(*)	3905 ^(*)

(*) With Gear Operator.

(**) BW ends, short pattern.

Dimensions in mm and weight in kg.

Weights and dimensions can be changed without notice.

Bigger sizes available under customer request.

ASME B16.34 PRESSURE SEAL

Class 2500

VC2500PS

Sizes 2" to 12"

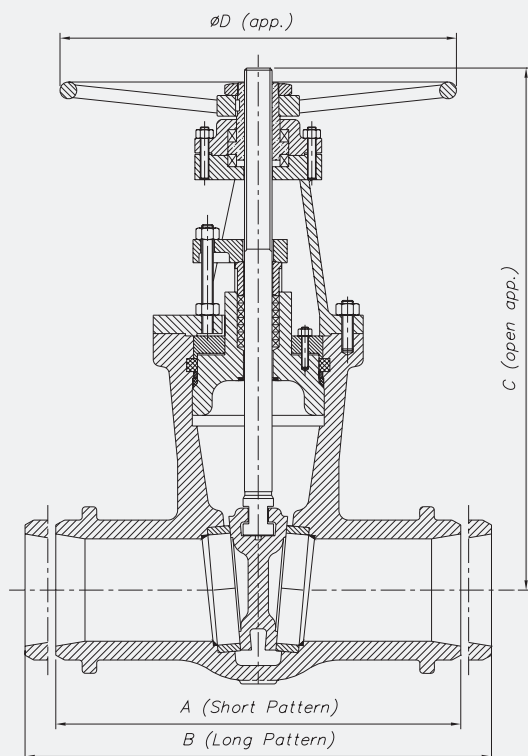

* Long pattern available with flanges.

TRIM

API 600 TRIM N°	Nominal TRIM	Stem / Backseat	Seating Surface Body / Wedge
1	F6	13Cr	13Cr
2	304	18Cr-8Ni	18Cr-8Ni
3	F310	25Cr-20Ni	25Cr-20Ni
4	Hard F6	13Cr	Hard 13Cr
5	Hardfaced	13Cr	Co-Cr A
5A	Hardfaced	13Cr	Ni-Cr
6	F6 and Cu-Ni	13Cr	13Cr and Cu-Ni
7	F6 and Hard F6	13Cr	13Cr and Hard 13Cr
8	F6 and Hardfaced	13Cr	13Cr and Co-Cr A
8A	F6 and Hardfaced	13Cr	13Cr and Ni-Cr
9	Monel	Ni-Cu Alloy	Ni-Cu Alloy
10	316	18Cr-8Ni-Mo	18Cr-8Ni-Mo
11	Monel and Hardfaced	Ni-Cu Alloy	Ni-Cu Alloy and Trim 5 or 5A
12	316 and Hardfaced	18Cr-8Ni-Mo	18Cr-8Ni-Mo and Trim 5 or 5A
13	Alloy 20	19Cr-29Ni	19Cr-29Ni
14	Alloy 20 and Hardfaced	19Cr-29Ni	19Cr-29Ni and Trim 5 or 5A
15	Hardfaced	18Cr-8Ni	Co-Cr A
16	Hardfaced	18Cr-8Ni-Mo	Co-Cr A
17	Hardfaced	18Cr-10Ni-Cb	Co-Cr A
18	Hardfaced	19Cr-29Ni	Co-Cr A

HF: Hard Facing using CoCr welding alloy (Stellite)

Materials

ACC. / ASME B16.34
 DI, WCB, WCC, WC1, WC6, WC9, C5, C12, LCB, LCC, CF8, CF8C, CF8M, CF3, CF3M,
 DUPLEX, SUPERDUPLEX, EXOTIC MATERIALS.

General dimensions

DN	A	B	C	ØD	WEIGHT (App.) ^(**)
50 (2")	279	451	585	250	90
65 (2½")	330	508	710	350	120
80 (3")	368	578	820	350	155
100 (4")	457	673	895	400	315
125 (5")	533	794	980	500	395
150 (6")	610	914	1060	500 ^(*)	525 ^(*)
200 (8")	762	1022	1310	710 ^(*)	980 ^(*)
250 (10")	914	1270	1480	710 ^(*)	1315 ^(*)
300 (12")	1041	1422	1520	760 ^(*)	1850 ^(*)

(*) With Gear Operator.

(**) BW ends, short pattern.

Dimensions in mm and weight in kg.

Weights and dimensions can be changed without notice.

Bigger sizes available under customer request.

| GATE, GLOBE & CHECK VALVES |

GLOBE VALVES

2" - 16" | Class 150 - Class 2500



All globe valves utilize the “port closure” concept of valves. By this it meant that fluid passes through a specific opening (rather than a general passageway, as in the case of gate valves), and the fluid is controlled by means of a stem-mounted disc or inserted plug in that area.

Despite of lacking the straight through, unobstructed passageway of the gate valve, these globe types are superior in two key aspects - throttling and serviceability under frequent use. They are better at the throttling function because they permit fluid to exit uniformly around the circumference of a seat, rather than “slicing” down to limit passage through a narrowly restricted area.

BILL OF MATERIALS		TRIM 8	TRIM 2	TRIM 8	TRIM 10
Item	Description	Carbon Steel	Carbon Steel (Low Temp.)	Alloy Steel	Stainless Steel
1	Body	A 216 Gr. WCB	A 352 Gr. LCB	A 217 Gr. C5	A 351 Gr. CF8M
2	Bonnet	A 216 Gr. WCB	A 352 Gr. LCB	A 217 Gr. C5	A 351 Gr. CF8M
4	Disc	A105 + ER 410	A 182 Gr. F304	A 217 Gr. C5 + ER 410	A 351 Gr. CF8M
5	Seat Ring	A105 + Stellite	A 182 Gr. F304	A182 Gr. F6a + Stellite	----
6	Backseat	A182 Gr. F6a	A 182 Gr. F304	A182 Gr. F6a	----
7	Stem	A182 Gr. F6a	A 182 Gr. F304	A182 Gr. F6a	A 182 Gr. F316
8	Gland	A 105	A 105	A182 Gr. F6a	A 182 Gr. F316
9	Gland Flange	A 105	A 105	A 105	A 182 Gr. F304
11	Stem Nut	B 148 / A 439 Gr. D2	B 148 / A 439 Gr. D2	B 148 / A 439 Gr. D2	B 148 / A 439 Gr. D2
12	Disc Nut	A 182 Gr. F6a	A 182 Gr. F304	A 182 Gr. F6a	A 182 Gr. F316
18	Handwheel	Carbon Steel	Carbon Steel	Carbon Steel	Carbon Steel
19	Handwheel Nut	Steel	Steel	Steel	Steel
20	Bonnet Bolt & Nut	A 193 Gr.B7 / A 194 Gr.2H	A320 Gr. L7 / A194 Gr. 7	A 193 Gr.B7 / A 194 Gr.2H	A 193 Gr.B7 / A 194 Gr.2H ⁽¹⁾
21	Eye Bolt & Nut	A 193 Gr.B7 / A 194 Gr.2H	A 193 Gr.B7 / A 194 Gr.2H	A 193 Gr.B7 / A 194 Gr.2H	A 193 Gr.B7 / A 194 Gr.2H
28	Gasket (Class 150)	SS304 / Graphite	SS304 / Graphite	SS304 / Graphite	SS316 / Graphite
28	Gasket (Class 300)	Spw SS304 / Graphite	Spw SS304 / Graphite	Spw SS304 / Graphite	Spw SS316/Graphite
28	Gasket (Class 600)	Spw SS304 / Graphite	Spw SS304 / Graphite	Spw SS304 / Graphite	Spw SS316/Graphite
28	Gasket (Class 900)	RJ SS304	RJ SS304	RJ SS304	RJ SS316
28	Gasket (Class 1500)	RJ SS304	RJ SS304	RJ SS304	RJ SS316
28	Gasket (Class 2500)	RJ SS304	RJ SS304	RJ SS304	RJ SS316
29	Stem Packing	Graphite	Graphite	Graphite	Graphite
37	Thrust Washer	A 182 Gr. F6a	A 182 Gr. F304	A 182 Gr. F6a	A 182 Gr. F316
38	Washer	Steel	Steel	Steel	Steel
42	Grub Screw	A 193 Gr. B7	A 193 Gr. B7	A 193 Gr. B7	A 193 Gr. B7
45	Lock Nut	Steel	Steel	A 182 Gr. F6a	A 182 Gr. F316

* Standard construction with trim 8,2 and 10. Others constructions are available.
(1) Zinc coating.

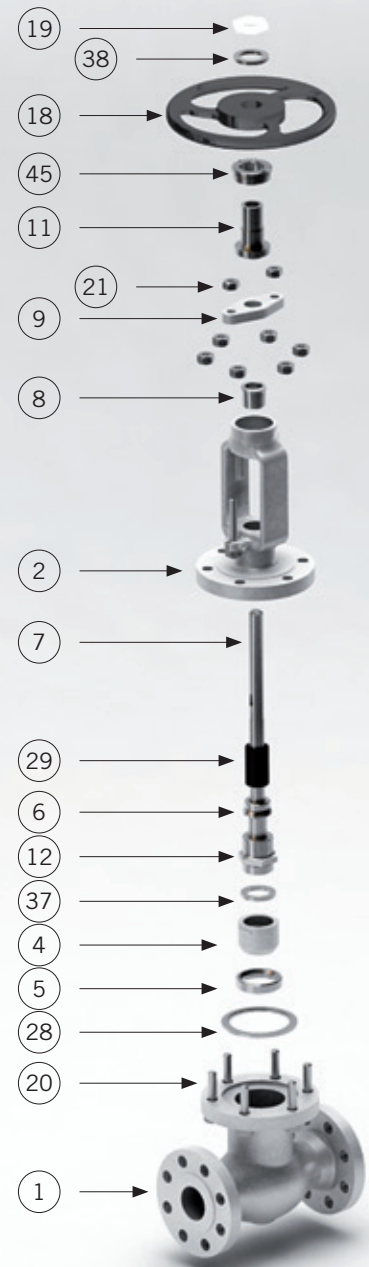

SHIFTS

Stem

The stems of JC globe valves are forged from one piece and ACME threaded, then mechanized and finally provided with a smooth finishing in order to minimize friction.

Body and Bonnet Gasket

The design of the body-bonnet gasket varies depending on the class of the valve.

Class 150 to 600 globe valves consist of a circular male-female connection with a graphite or spiral wound gasket.

Class 900 and above globe valves consist of a ring type joint.

In pressure seal designs the sealing is achieved through a gasket that takes advantage of the internal pressure of the line. The material most commonly used is high-purity graphite being located between the body and the body retainer ring.

Body and Bonnet

Bodies and bonnets are high quality cast and afterwards precisely machined, directing the attention to prevent stress concentration.

Bonnets are made either of one piece only –the yoke then being an integral part of it – or have two pieces, depending on the size of the valve. This ensures the perfect alignment with the body what leads to an accurate opening and closing.

Bodies of globe valves are designed considering the same characteristics as gate valves, which in this case means that the disc is guided in bigger valve sizes or high pressure service in order to avoid vibrations and better seat.

Backseat

All JC gate and globe valves have backseat threaded in the bonnet, or for the pressure seal valves, welded to the bonnet. The hard facing is stellite 6 or equivalent.

DESIGN STANDARDS

Bolted Bonnet Globe Valve	ASME B16.34
Bolted Bonnet Globe Valve	BS 1873 & ASME B16.34
Pressure Seal Globe Valve (Long & Short pattern)	ASME B16.34
Face to Face / End to End Dimensions	ASME B16.10 / ISO 5752
End Flanged dimensions	ASME B16.5 / ISO 7005-1, ASME B16.47-A&B MSS SP- 44 & API 605
Butt-weld End dimensions	ASME B16.25
Valve inspection & testing	BS1873, ISO 5208, BS 6755, EN 17266
Pressure - Temperature rating	ASME B16.34

TEST / INSPECTION METHODS & ACCEPTANCE CRITERIA

TEST / INSPECTION	METHOD	ACCEPTANCE CRITERIA
Visual Inspection		MSS SP-55
Marking		MSS SP-25 & ISO5208
Dimensional Inspection		Aplicable valve
Chemical Analysis	ASTM E350	Aplicable Standard
Mechanical Properties	ASTM A370	Aplicable Standard
Liquid Penetrant Inspection	ASTM A165	ASME B16.34
Magnetic Particle Inspection	ASTM E709	ASME B16.34
Radiographic Inspection	ASME B16.34	ASME B16.34
Ultrasonic Inspection	ASTM A388	ASME B16.34
Pressure Testing	API 598 / ISO 5208	API 598 / ISO 5208

BS1873 BOLTED BONNET

Class 150

VG150BB

Sizes 2" to 16"

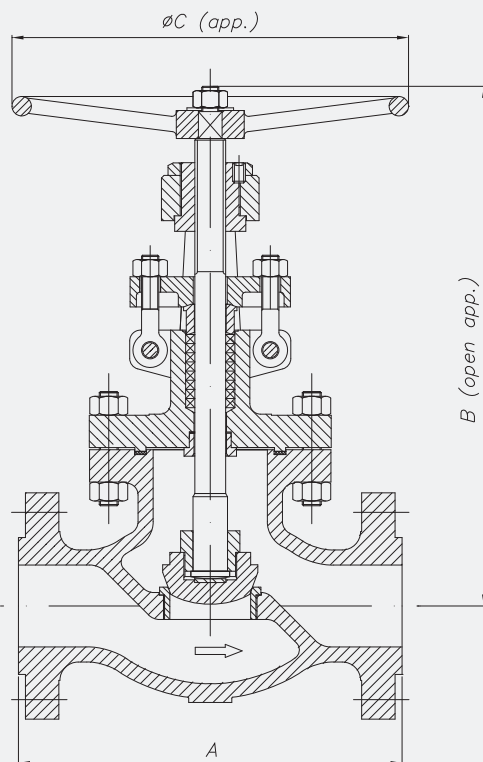

TRIM

API 600 TRIM N°	Nominal TRIM	Stem / Backseat	Seating Surface Body / Wedge
1	F6	13Cr	13Cr
2	304	18Cr-8Ni	18Cr-8Ni
3	F310	25Cr-20Ni	25Cr-20Ni
4	Hard F6	13Cr	Hard 13Cr
5	Hardfaced	13Cr	Co-Cr A
5A	Hardfaced	13Cr	Ni-Cr
6	F6 and Cu-Ni	13Cr	13Cr and Cu-Ni
7	F6 and Hard F6	13Cr	13Cr and Hard 13Cr
8	F6 and Hardfaced	13Cr	13Cr and Co-Cr A
8A	F6 and Hardfaced	13Cr	13Cr and Ni-Cr
9	Monel	Ni-Cu Alloy	Ni-Cu Alloy
10	316	18Cr-8Ni-Mo	18Cr-8Ni-Mo
11	Monel and Hardfaced	Ni-Cu Alloy	Ni-Cu Alloy and Trim 5 or 5A
12	316 and Hardfaced	18Cr-8Ni-Mo	18Cr-8Ni-Mo and Trim 5 or 5A
13	Alloy 20	19Cr-29Ni	19Cr-29Ni
14	Alloy 20 and Hardfaced	19Cr-29Ni	19Cr-29Ni and Trim 5 or 5A
15	Hardfaced	18Cr-8Ni	Co-CrR A
16	Hardfaced	18Cr-8Ni-Mo	Co-CrR A
17	Hardfaced	18Cr-10Ni-Cb	Co-CrR A
18	Hardfaced	19Cr-29Ni	Co-CrR A

HF: Hard Facing using CoCr welding alloy (Stellite)

Materials

ACC. / ASME B16.34
 DI, WCB, WCC, WC1, WC6, WC9, C5, C12, LCB, LCC, CF8, CF8C, CF8M, CF3, CF3M,
 DUPLEX, SUPERDUPLEX, EXOTIC MATERIALS.

General dimensions

DN	A (RF / BW)	B	ØC	WEIGHT (App.)
50 (2")	203	341	200	22
65 (2½")	216	367	250	29
80 (3")	241	375	250	40
100 (4")	292	483	300	64
125 (5")	356	537	300	77
150 (6")	406	517	350	105
200 (8")	495	590	400	154
250 (10")	622	754	450	288
300 (12")	698	941	640	507
350 (14")	787	1085	640	520
400 (16")	914	1250	460 ^(*)	810 ^(*)

^(*) With Gear Operator.
 Dimensions in mm and weight in kg.
 Weights and dimensions can be changed without notice.
 Bigger sizes available under customer request.

BS1873 BOLTED BONNET

Class 300

VG300BB

Sizes 2" to 12"

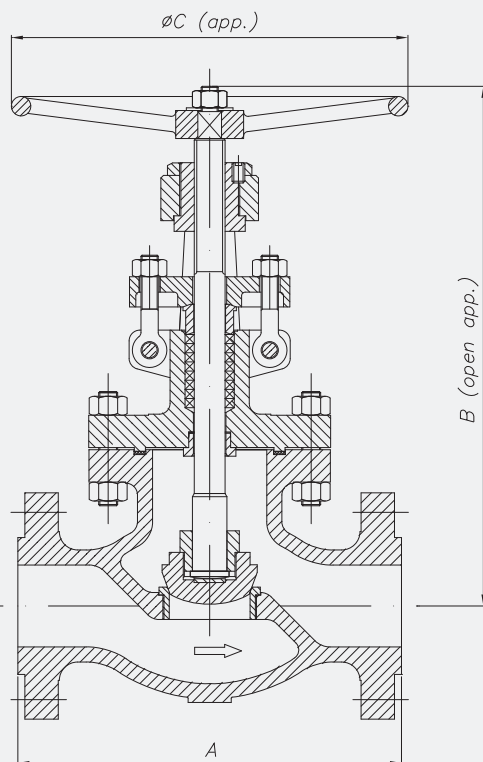

TRIM

API 600 TRIM N°	Nominal TRIM	Stem / Backseat	Seating Surface Body / Wedge
1	F6	13Cr	13Cr
2	304	18Cr-8Ni	18Cr-8Ni
3	F310	25Cr-20Ni	25Cr-20Ni
4	Hard F6	13Cr	Hard 13Cr
5	Hardfaced	13Cr	Co-Cr A
5A	Hardfaced	13Cr	Ni-Cr
6	F6 and Cu-Ni	13Cr	13Cr and Cu-Ni
7	F6 and Hard F6	13Cr	13Cr and Hard 13Cr
8	F6 and Hardfaced	13Cr	13Cr and Co-Cr A
8A	F6 and Hardfaced	13Cr	13Cr and Ni-Cr
9	Monel	Ni-Cu Alloy	Ni-Cu Alloy
10	316	18Cr-8Ni-Mo	18Cr-8Ni-Mo
11	Monel and Hardfaced	Ni-Cu Alloy	Ni-Cu Alloy and Trim 5 or 5A
12	316 and Hardfaced	18Cr-8Ni-Mo	18Cr-8Ni-Mo and Trim 5 or 5A
13	Alloy 20	19Cr-29Ni	19Cr-29Ni
14	Alloy 20 and Hardfaced	19Cr-29Ni	19Cr-29Ni and Trim 5 or 5A
15	Hardfaced	18Cr-8Ni	Co-Cr A
16	Hardfaced	18Cr-8Ni-Mo	Co-Cr A
17	Hardfaced	18Cr-10Ni-Cb	Co-Cr A
18	Hardfaced	19Cr-29Ni	Co-Cr A

HF: Hard Facing using CoCr welding alloy (Stellite)

Materials

ACC. / ASME B16.34
 DI, WCB, WCC, WC1, WC6, WC9, C5, C12, LCB, LCC, CF8, CF8C, CF8M, CF3, CF3M,
 DUPLEX, SUPERDUPLEX, EXOTIC MATERIALS.

General dimensions

DN	A (RF / BW)	B	ØC	WEIGHT (App.)
50 (2")	267	349	200	31
65 (2½")	292	376	250	43
80 (3")	318	430	250	57
100 (4")	356	486	350	86
125 (5")	400	560	400	130
150 (6")	444	618	450	168
200 (8")	559	937	560	280
250 (10")	622	949	640	385
300 (12")	711	995	460 (*)	671 (*)

(*) With Gear Operator.

Dimensions in mm and weight in kg.

Weights and dimensions can be changed without notice.

Bigger sizes available under customer request.

BS1873 BOLTED BONNET

Class 600

VG600BB

Sizes 2" to 12"

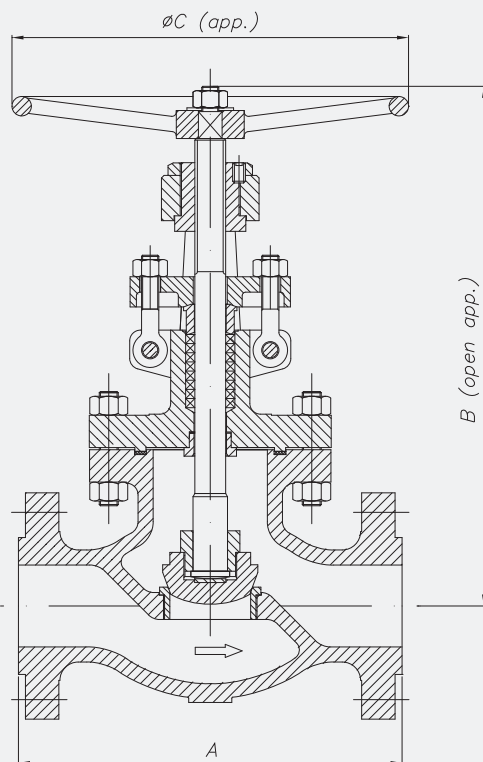

TRIM

API 600 TRIM N°	Nominal TRIM	Stem / Backseat	Seating Surface Body / Wedge
1	F6	13Cr	13Cr
2	304	18Cr-8Ni	18Cr-8Ni
3	F310	25Cr-20Ni	25Cr-20Ni
4	Hard F6	13Cr	Hard 13Cr
5	Hardfaced	13Cr	Co-Cr A
5A	Hardfaced	13Cr	Ni-Cr
6	F6 and Cu-Ni	13Cr	13Cr and Cu-Ni
7	F6 and Hard F6	13Cr	13Cr and Hard 13Cr
8	F6 and Hardfaced	13Cr	13Cr and Co-Cr A
8A	F6 and Hardfaced	13Cr	13Cr and Ni-Cr
9	Monel	Ni-Cu Alloy	Ni-Cu Alloy
10	316	18Cr-8Ni-Mo	18Cr-8Ni-Mo
11	Monel and Hardfaced	Ni-Cu Alloy	Ni-Cu Alloy and Trim 5 or 5A
12	316 and Hardfaced	18Cr-8Ni-Mo	18Cr-8Ni-Mo and Trim 5 or 5A
13	Alloy 20	19Cr-29Ni	19Cr-29Ni
14	Alloy 20 and Hardfaced	19Cr-29Ni	19Cr-29Ni and Trim 5 or 5A
15	Hardfaced	18Cr-8Ni	Co-CrR A
16	Hardfaced	18Cr-8Ni-Mo	Co-CrR A
17	Hardfaced	18Cr-10Ni-Cb	Co-CrR A
18	Hardfaced	19Cr-29Ni	Co-CrR A

HF: Hard Facing using CoCr welding alloy (Stellite)

Materials

ACC. / ASME B16.34
 DI, WCB, WCC, WC1, WC6, WC9, C5, C12, LCB, LCC, CF8, CF8C, CF8M, CF3, CF3M,
 DUPLEX, SUPERDUPLEX, EXOTIC MATERIALS.

General dimensions

DN	A (RF / BW)	B	ØC	WEIGHT (App.)
50 (2")	292	425	250	35
65 (2½")	330	502	300	48
80 (3")	356	521	350	73
100 (4")	432	620	450	117
125 (5")	508	756	500	245
150 (6")	559	886	560	327
200 (8")	660	932	460 (*)	482 (*)
250 (10")	787	1040	610 (*)	700 (*)
300 (12")	838	1280	760 (*)	900 (*)

(*) With Gear Operator.

Dimensions in mm and weight in kg.

Weights and dimensions can be changed without notice.

Bigger sizes available under customer request.

BS1873 BOLTED BONNET

Class 900

VG900BB

Sizes 2" to 8"

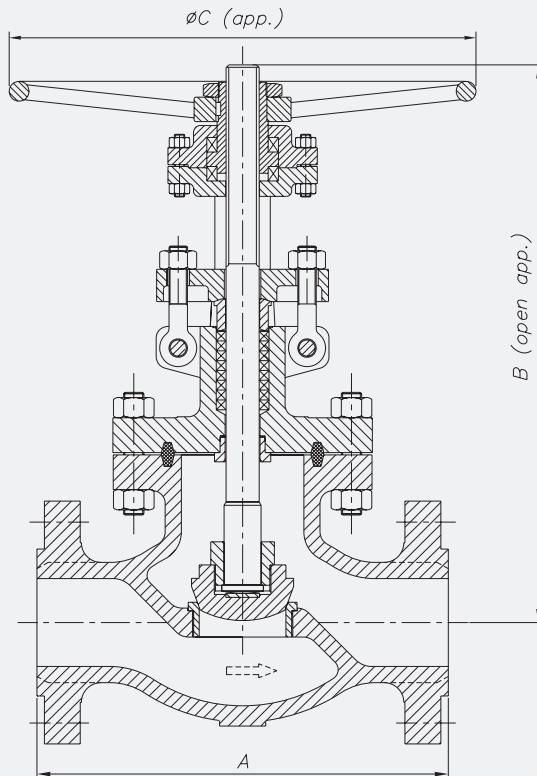

TRIM

API 600 TRIM N°	Nominal TRIM	Stem / Backseat	Seating Surface Body / Wedge
1	F6	13Cr	13Cr
2	304	18Cr-8Ni	18Cr-8Ni
3	F310	25Cr-20Ni	25Cr-20Ni
4	Hard F6	13Cr	Hard 13Cr
5	Hardfaced	13Cr	Co-Cr A
5A	Hardfaced	13Cr	Ni-Cr
6	F6 and Cu-Ni	13Cr	13Cr and Cu-Ni
7	F6 and Hard F6	13Cr	13Cr and Hard 13Cr
8	F6 and Hardfaced	13Cr	13Cr and Co-Cr A
8A	F6 and Hardfaced	13Cr	13Cr and Ni-Cr
9	Monel	Ni-Cu Alloy	Ni-Cu Alloy
10	316	18Cr-8Ni-Mo	18Cr-8Ni-Mo
11	Monel and Hardfaced	Ni-Cu Alloy	Ni-Cu Alloy and Trim 5 or 5A
12	316 and Hardfaced	18Cr-8Ni-Mo	18Cr-8Ni-Mo and Trim 5 or 5A
13	Alloy 20	19Cr-29Ni	19Cr-29Ni
14	Alloy 20 and Hardfaced	19Cr-29Ni	19Cr-29Ni and Trim 5 or 5A
15	Hardfaced	18Cr-8Ni	Co-Cr A
16	Hardfaced	18Cr-8Ni-Mo	Co-Cr A
17	Hardfaced	18Cr-10Ni-Cb	Co-Cr A
18	Hardfaced	19Cr-29Ni	Co-Cr A

HF: Hard Facing using CoCr welding alloy (Stellite)

Materials

ACC. / ASME B16.34
 DI, WCB, WCC, WC1, WC6, WC9, C5, C12, LCB, LCC, CF8, CF8C, CF8M, CF3, CF3M,
 DUPLEX, SUPERDUPLEX, EXOTIC MATERIALS.

General dimensions

DN	A (RF / BW)	B	ØC	WEIGHT (App.)
50 (2")	368	478	350	105
65 (2½")	419	550	350	120
80 (3")	381	614	450	131
100 (4")	457	789	560	218
125 (5")	559	825	560	235
150 (6")	610	886	460 (*)	452 (*)
200 (8")	737	932	610 (*)	710 (*)

(*) With Gear Operator.

Dimensions in mm and weight in kg.

Weights and dimensions can be changed without notice.

Bigger sizes available under customer request.

BS1873 BOLTED BONNET

Class 1500

VG1500BB

Sizes 2" to 8"

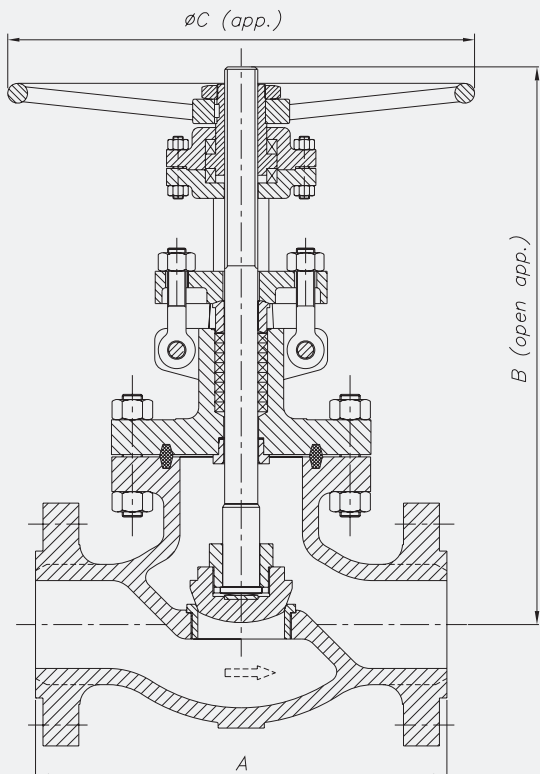

TRIM

API 600 TRIM N°	Nominal TRIM	Stem / Backseat	Seating Surface Body / Wedge
1	F6	13Cr	13Cr
2	304	18Cr-8Ni	18Cr-8Ni
3	F310	25Cr-20Ni	25Cr-20Ni
4	Hard F6	13Cr	Hard 13Cr
5	Hardfaced	13Cr	Co-Cr A
5A	Hardfaced	13Cr	Ni-Cr
6	F6 and Cu-Ni	13Cr	13Cr and Cu-Ni
7	F6 and Hard F6	13Cr	13Cr and Hard 13Cr
8	F6 and Hardfaced	13Cr	13Cr and Co-Cr A
8A	F6 and Hardfaced	13Cr	13Cr and Ni-Cr
9	Monel	Ni-Cu Alloy	Ni-Cu Alloy
10	316	18Cr-8Ni-Mo	18Cr-8Ni-Mo
11	Monel and Hardfaced	Ni-Cu Alloy	Ni-Cu Alloy and Trim 5 or 5A
12	316 and Hardfaced	18Cr-8Ni-Mo	18Cr-8Ni-Mo and Trim 5 or 5A
13	Alloy 20	19Cr-29Ni	19Cr-29Ni
14	Alloy 20 and Hardfaced	19Cr-29Ni	19Cr-29Ni and Trim 5 or 5A
15	Hardfaced	18Cr-8Ni	Co-CrR A
16	Hardfaced	18Cr-8Ni-Mo	Co-CrR A
17	Hardfaced	18Cr-10Ni-Cb	Co-CrR A
18	Hardfaced	19Cr-29Ni	Co-CrR A

HF: Hard Facing using CoCr welding alloy (Stellite)

Materials

ACC. / ASME B16.34
 DI, WCB, WCC, WC1, WC6, WC9, C5, C12, LCB, LCC, CF8, CF8C, CF8M, CF3, CF3M,
 DUPLEX, SUPERDUPLEX, EXOTIC MATERIALS.

General dimensions

DN	A (RF / BW)	B	ØC	WEIGHT (App.)
50 (2")	368	592	350	112
65 (2½")	419	605	450	175
80 (3")	470	692	450	228
100 (4")	546	907	460 (*)	336 (*)
125 (5")	673	965	560 (*)	585 (*)
150 (6")	705	1015	610 (*)	822 (*)
200 (8")	832	1145	610 (*)	960 (*)

(*) With Gear Operator.

Dimensions in mm and weight in kg.
 Weights and dimensions can be changed without notice.
 Bigger sizes available under customer request.

BS1873 BOLTED BONNET

Class 2500

VG2500BB

Sizes 2" to 8"

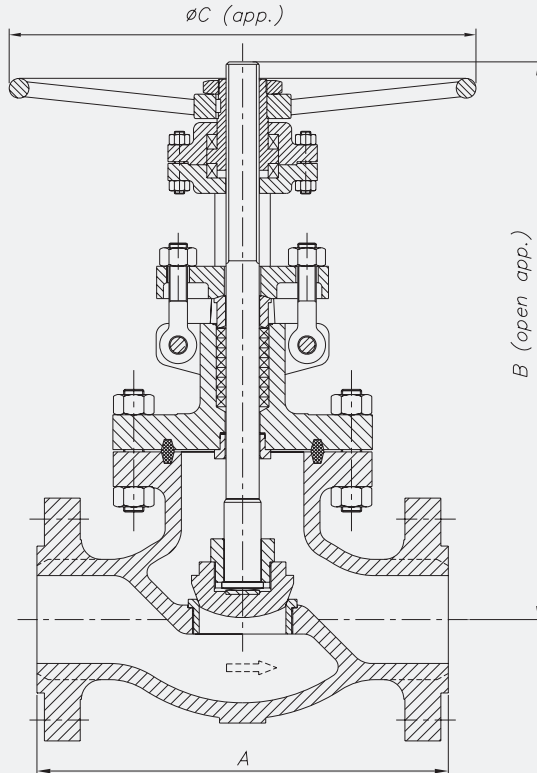

TRIM

API 600 TRIM N°	Nominal TRIM	Stem / Backseat	Seating Surface Body / Wedge
1	F6	13Cr	13Cr
2	304	18Cr-8Ni	18Cr-8Ni
3	F310	25Cr-20Ni	25Cr-20Ni
4	Hard F6	13Cr	Hard 13Cr
5	Hardfaced	13Cr	Co-Cr A
5A	Hardfaced	13Cr	Ni-Cr
6	F6 and Cu-Ni	13Cr	13Cr and Cu-Ni
7	F6 and Hard F6	13Cr	13Cr and Hard 13Cr
8	F6 and Hardfaced	13Cr	13Cr and Co-Cr A
8A	F6 and Hardfaced	13Cr	13Cr and Ni-Cr
9	Monel	Ni-Cu Alloy	Ni-Cu Alloy
10	316	18Cr-8Ni-Mo	18Cr-8Ni-Mo
11	Monel and Hardfaced	Ni-Cu Alloy	Ni-Cu Alloy and Trim 5 or 5A
12	316 and Hardfaced	18Cr-8Ni-Mo	18Cr-8Ni-Mo and Trim 5 or 5A
13	Alloy 20	19Cr-29Ni	19Cr-29Ni
14	Alloy 20 and Hardfaced	19Cr-29Ni	19Cr-29Ni and Trim 5 or 5A
15	Hardfaced	18Cr-8Ni	Co-Cr A
16	Hardfaced	18Cr-8Ni-Mo	Co-Cr A
17	Hardfaced	18Cr-10Ni-Cb	Co-Cr A
18	Hardfaced	19Cr-29Ni	Co-Cr A

HF: Hard Facing using CoCr welding alloy (Stellite)

Materials

ACC. / ASME B16.34
 DI, WCB, WCC, WC1, WC6, WC9, C5, C12, LCB, LCC, CF8, CF8C, CF8M, CF3, CF3M,
 DUPLEX, SUPERDUPLEX, EXOTIC MATERIALS.

General dimensions

DN	A (RF / BW)	B	ØC	WEIGHT (App.)
50 (2")	451	635	350	135
65 (2½")	508	690	450	270
80 (3")	578	745	460	335
100 (4")	673	975	560 ^(*)	510 ^(*)
125 (5")	794	1025	610 ^(*)	730 ^(*)
150 (6")	914	1105	610 ^(*)	995 ^(*)
200 (8")	1022	1225	610 ^(*)	1185 ^(*)

^(*) With Gear Operator.

Dimensions in mm and weight in kg.

Weights and dimensions can be changed without notice.

Bigger sizes available under customer request.

| GATE, GLOBE & CHECK VALVES |

GLOBE VALVES

PRESSURE SEAL

2" - 16" | Class 900 - Class 2500

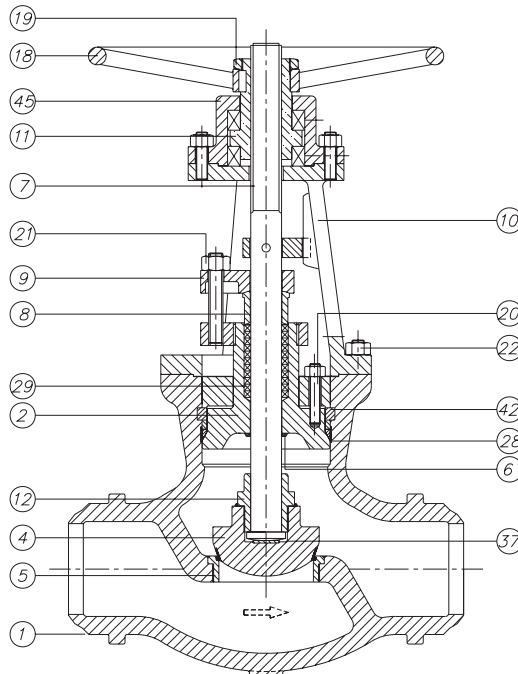

BILL OF MATERIALS		TRIM 8	TRIM 2	TRIM 8	TRIM 10
Item	Description	Carbon Steel	Carbon Steel (Low Temp.)	Alloy Steel	Stainless Steel
1	Body	A 216 Gr. WCB	A 352 Gr. LCB	A 217 Gr. C5	A 351 Gr. CF8M
2	Bonnet	A 216 Gr. WCB	A 352 Gr. LCB	A 217 Gr. C5	A 351 Gr. CF8M
4	Disc	A105 + Stellite	A182 Gr. F304 + Stellite	A 217 Gr. C5 + Stellite	A182 Gr. F316 + Stellite
5	Seat Ring	A105 + Stellite	A182 Gr. F304 + Stellite	A182 Gr. F6a + Stellite	A182F316 + Stellite
6	Backseat	Stellite	Stellite	Stellite	Stellite
7	Stem	A182 Gr. F6a	A182 Gr. F304	A182 Gr. F6a	A 182 Gr. F316
8	Gland	A105	A105	A182 Gr. F6a	A 182 Gr. F316
9	Gland Flange	A 105	A 105	A 105	A 182 Gr. F304
10	Yoke	A 216 Gr. WCB	A 352 Gr. LCB	A 217 Gr. C5	A 351 Gr. CF8M
11	Stem Nut	B148 / A 439 Gr. D2	B148 / A 439 Gr. D2	B148 / A 439 Gr. D2	B148 / A 439 Gr. D2
12	Disc Nut	A182 Gr. F6a	A182 Gr. F304	A182 Gr. F6a	A182 Gr. F316
18	Handwheel	Carbon Steel	Carbon Steel	Carbon Steel	Carbon Steel
19	Handwheel Nut	Steel	Steel	Steel	Steel
20	Bonnet Bolt & Nut	A 193 Gr. B7 / A 194 Gr. 2H	A320 Gr. L7 / A194 Gr. 7	A 193 Gr. B7 / A 194 Gr. 2H	A 193 Gr. B7 / A 194 Gr. 2H ⁽¹⁾
21	Bolt & Nut	A 193 Gr. B7 / A 194 Gr. 2H	A 193 Gr. B7 / A 194 Gr. 2H	A 193 Gr. B7 / A 194 Gr. 2H	A 193 Gr. B7 / A 194 Gr. 2H
22	Yoke Bolt & Nut	A 193 Gr. B7 / A 194 Gr. 2H	A 193 Gr. B7 / A 194 Gr. 2H	A 193 Gr. B7 / A 194 Gr. 2H	A 193 Gr. B7 / A 194 Gr. 2H ⁽¹⁾
28	Gasket (Class 900)	Graphite or SS304L	Graphite or SS304L	Graphite or SS304L	Graphite or SS316L
28	Gasket (Class 1500)	Graphite or SS304L	Graphite or SS304L	Graphite or SS304L	Graphite or SS316L
28	Gasket (Class 2500)	Graphite or SS304L	Graphite or SS304L	Graphite or SS304L	Graphite or SS316L
29	Stem Packing	Graphite	Graphite	Graphite	Graphite
37	Thrust Washer	A182 Gr. F6a	A182 Gr. F304	A182 Gr. F6a	A182 Gr. F316
42	Segmental Ring	A 105	A182 Gr. F304	A182 Gr. F6a	A182 Gr. F316
45	Lock Nut	Steel	A182 Gr. F304	A182 Gr. F6a	A182 Gr. F316

(1) Zinc coating.

ASME B16.34 PRESSURE SEAL

Class 900

VG900PS

Sizes 2" to 16"

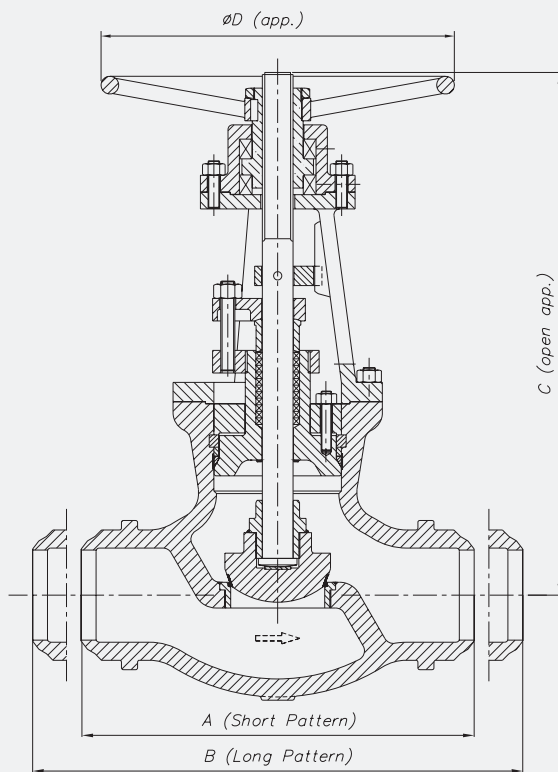

* Long pattern available with flanges.

TRIM

API 600 TRIM N°	Nominal TRIM	Stem / Backseat	Seating Surface Body / Wedge
1	F6	13Cr	13Cr
2	304	18Cr-8Ni	18Cr-8Ni
3	F310	25Cr-20Ni	25Cr-20Ni
4	Hard F6	13Cr	Hard 13Cr
5	Hardfaced	13Cr	Co-Cr A
5A	Hardfaced	13Cr	Ni-Cr
6	F6 and Cu-Ni	13Cr	13Cr and Cu-Ni
7	F6 and Hard F6	13Cr	13Cr and Hard 13Cr
8	F6 and Hardfaced	13Cr	13Cr and Co-Cr A
8A	F6 and Hardfaced	13Cr	13Cr and Ni-Cr
9	Monel	Ni-Cu Alloy	Ni-Cu Alloy
10	316	18Cr-8Ni-Mo	18Cr-8Ni-Mo
11	Monel and Hardfaced	Ni-Cu Alloy	Ni-Cu Alloy and Trim 5 or 5A
12	316 and Hardfaced	18Cr-8Ni-Mo	18Cr-8Ni-Mo and Trim 5 or 5A
13	Alloy 20	19Cr-29Ni	19Cr-29Ni
14	Alloy 20 and Hardfaced	19Cr-29Ni	19Cr-29Ni and Trim 5 or 5A
15	Hardfaced	18Cr-8Ni	Co-Cr A
16	Hardfaced	18Cr-8Ni-Mo	Co-Cr A
17	Hardfaced	18Cr-10Ni-Cb	Co-Cr A
18	Hardfaced	19Cr-29Ni	Co-Cr A

HF: Hard Facing using CoCr welding alloy (Stellite)

Materials

ACC. / ASME B16.34
 DI, WCB, WCC, WC1, WC6, WC9, C5, C12, LCB, LCC, CF8, CF8C, CF8M, CF3, CF3M,
 DUPLEX, SUPERDUPLEX, EXOTIC MATERIALS.

General dimensions

DN	A	B	C	ØD	WEIGHT (App.) (**)
50 (2")	216	368	460	350	90
65 (2½")	254	419	535	350	105
80 (3")	305	381	605	400	120
100 (4")	356	457	750	450	195
125 (5")	432	559	815	450	230
150 (6")	508	610	875	500 (*)	355 (*)
200 (8")	660	737	930	500 (*)	630 (*)
250 (10")	787	838	1095	640 (*)	885 (*)
300 (12")	914	965	1205	640 (*)	1135 (*)
350 (14")	991	1029	1310	710 (*)	1580 (*)
400 (16")	1092	1130	1425	710 (*)	2295 (*)

(*) With Gear Operator.

(**) BW ends, short pattern.

Dimensions in mm and weight in kg.

Weights and dimensions can be changed without notice.

Bigger sizes available under customer request.

ASME B16.34 PRESSURE SEAL

Class 1500

VG1500PS

Sizes 2" to 16"

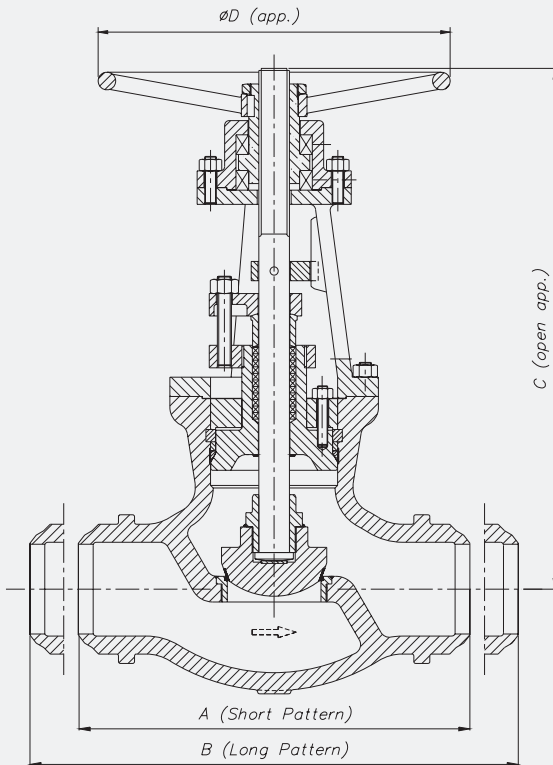

* Long pattern available with flanges.

TRIM

API 600 TRIM N°	Nominal TRIM	Stem / Backseat	Seating Surface Body / Wedge
1	F6	13Cr	13Cr
2	304	18Cr-8Ni	18Cr-8Ni
3	F310	25Cr-20Ni	25Cr-20Ni
4	Hard F6	13Cr	Hard 13Cr
5	Hardfaced	13Cr	Co-Cr A
5A	Hardfaced	13Cr	Ni-Cr
6	F6 and Cu-Ni	13Cr	13Cr and Cu-Ni
7	F6 and Hard F6	13Cr	13Cr and Hard 13Cr
8	F6 and Hardfaced	13Cr	13Cr and Co-Cr A
8A	F6 and Hardfaced	13Cr	13Cr and Ni-Cr
9	Monel	Ni-Cu Alloy	Ni-Cu Alloy
10	316	18Cr-8Ni-Mo	18Cr-8Ni-Mo
11	Monel and Hardfaced	Ni-Cu Alloy	Ni-Cu Alloy and Trim 5 or 5A
12	316 and Hardfaced	18Cr-8Ni-Mo	18Cr-8Ni-Mo and Trim 5 or 5A
13	Alloy 20	19Cr-29Ni	19Cr-29Ni
14	Alloy 20 and Hardfaced	19Cr-29Ni	19Cr-29Ni and Trim 5 or 5A
15	Hardfaced	18Cr-8Ni	Co-CrR A
16	Hardfaced	18Cr-8Ni-Mo	Co-CrR A
17	Hardfaced	18Cr-10Ni-Cb	Co-CrR A
18	Hardfaced	19Cr-29Ni	Co-CrR A

HF: Hard Facing using CoCr welding alloy (Stellite)

Materials

ACC. / ASME B16.34
 DI, WCB, WCC, WC1, WC6, WC9, C5, C12, LCB, LCC, CF8, CF8C, CF8M, CF3, CF3M,
 DUPLEX, SUPERDUPLEX, EXOTIC MATERIALS.

General dimensions

DN	A	B	C	ØD	WEIGHT (App.) (**)
50 (2")	216	368	592	350	82
65 (2½")	254	419	660	400	135
80 (3")	305	470	692	450	192
100 (4")	406	546	907	500 (*)	307 (*)
125 (5")	483	673	960	500 (*)	485 (*)
150 (6")	559	705	1015	640 (*)	659 (*)
200 (8")	711	832	1150	640 (*)	945 (*)
250 (10")	864	991	1350	710 (*)	1080 (*)
300 (12")	991	1130	1740	710 (*)	1505 (*)
350 (14")	1067	1257	2095	760 (*)	2240 (*)
400 (16")	1194	1384	2490	760 (*)	3450 (*)

(*) With Gear Operator.

(**) BW ends, short pattern.

Dimensions in mm and weight in kg.

Weights and dimensions can be changed without notice.

Bigger sizes available under customer request.

ASME B16.34 PRESSURE SEAL

Class 2500

VG2500PS

Sizes 2" to 12"

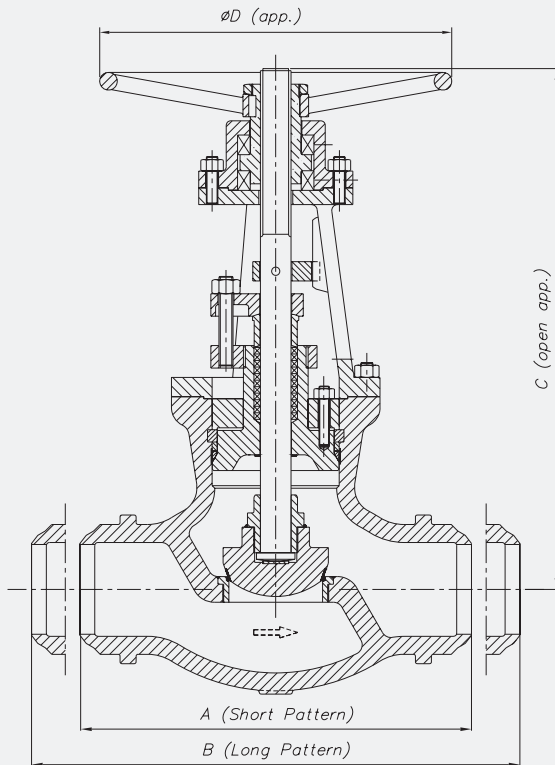

* Long pattern available with flanges.

TRIM

API 600 TRIM N°	Nominal TRIM	Stem / Backseat	Seating Surface Body / Wedge
1	F6	13Cr	13Cr
2	304	18Cr-8Ni	18Cr-8Ni
3	F310	25Cr-20Ni	25Cr-20Ni
4	Hard F6	13Cr	Hard 13Cr
5	Hardfaced	13Cr	Co-Cr A
5A	Hardfaced	13Cr	Ni-Cr
6	F6 and Cu-Ni	13Cr	13Cr and Cu-Ni
7	F6 and Hard F6	13Cr	13Cr and Hard 13Cr
8	F6 and Hardfaced	13Cr	13Cr and Co-Cr A
8A	F6 and Hardfaced	13Cr	13Cr and Ni-Cr
9	Monel	Ni-Cu Alloy	Ni-Cu Alloy
10	316	18Cr-8Ni-Mo	18Cr-8Ni-Mo
11	Monel and Hardfaced	Ni-Cu Alloy	Ni-Cu Alloy and Trim 5 or 5A
12	316 and Hardfaced	18Cr-8Ni-Mo	18Cr-8Ni-Mo and Trim 5 or 5A
13	Alloy 20	19Cr-29Ni	19Cr-29Ni
14	Alloy 20 and Hardfaced	19Cr-29Ni	19Cr-29Ni and Trim 5 or 5A
15	Hardfaced	18Cr-8Ni	Co-Cr A
16	Hardfaced	18Cr-8Ni-Mo	Co-Cr A
17	Hardfaced	18Cr-10Ni-Cb	Co-Cr A
18	Hardfaced	19Cr-29Ni	Co-Cr A

HF: Hard Facing using CoCr welding alloy (Stellite)

Materials

ACC. / ASME B16.34
 DI, WCB, WCC, WC1, WC6, WC9, C5, C12, LCB, LCC, CF8, CF8C, CF8M, CF3, CF3M,
 DUPLEX, SUPERDUPLEX, EXOTIC MATERIALS.

General dimensions

DN	A	B	C	ØD	WEIGHT (App.) ^(*)
50 (2")	279	451	620	350	95
65 (2½")	330	508	705	400	175
80 (3")	368	578	750	450	265
100 (4")	457	673	980	500 ^(*)	385 ^(*)
125 (5")	533	794	1060	500 ^(*)	480 ^(*)
150 (6")	610	914	1130	640 ^(*)	685 ^(*)
200 (8")	762	1022	1285	710 ^(*)	870 ^(*)
250 (10")	914	1270	1490	710 ^(*)	1450 ^(*)
300 (12")	1041	1422	1680	760 ^(*)	2105 ^(*)

^(*) With Gear Operator.^(**) BW ends, short pattern.

Dimensions in mm and weight in kg.

Weights and dimensions can be changed without notice.

Bigger sizes available under customer request.

| GATE, GLOBE & CHECK VALVES |

CHECK VALVES

2" - 36" | Class 150 - Class 2500



While not a valve in the traditional sense, check valves serve an important application—namely to prevent flow in one direction while allowing it in the other. A check valve is self-actuated and designed to prevent fluid from flowing back into the system (prevent reverse flow). Real-life applications include preventing backflow into an injection line or into a pump. The fluid flow opens the valve by forcing a disk or ball in one direction. When the flow stops, the disk or ball is seated and closes the valve. They can be installed in horizontal or vertical upward flow piping.

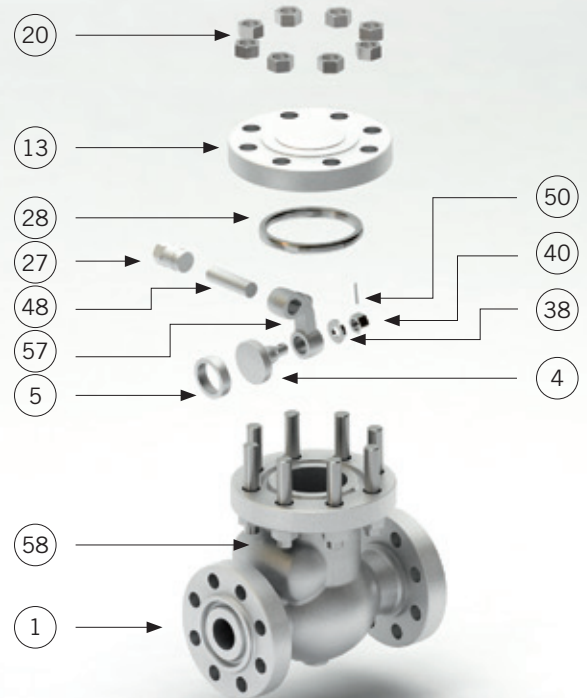

BILL OF MATERIALS		TRIM 8	TRIM 2	TRIM 8	TRIM 10
Item	Description	Carbon Steel	Carbon Steel (Low Temp.)	Alloy Steel	Stainless Steel
1	Body	A 216 Gr. WCB	A 352 Gr. LCB	A 217 Gr. C5	A 351 Gr. CF8M
4	Disc	A105 + ER 410	A 182 Gr. F304	A 182 Gr. F6a	A 182 Gr.F316
5	Seat Ring	A105 + Stellite	A 182 Gr. F304	A 182 Gr. F6a + Stellite	----
13	Cover	A 216 Gr.WCB / A 515 Gr.70	A 352 Gr.LCB / A 182 Gr.F304	A 217 Gr. C5	A 351 Gr. CF8M
20	Cover Bolt & Nut	A 193 Gr.B7 / A 194 Gr.2H	A 320 Gr.L7 / A 194 Gr.7	A 193 Gr.B7 / A 194 Gr.2H	A 193 Gr.B7 / A 194 Gr.2H ⁽¹⁾
27	Bracket Stud & Nut	A 193 Gr.B8 / A 194 Gr.8	A 193 Gr.B8 / A 194 Gr.8	A 193 Gr.B8 / A 194 Gr.8	A 193 Gr.B8M / A 194 Gr.8M
28	Gasket	SPW S.S. 304 / Graphite	SPW S.S. 304 / Graphite	SPW S.S. 304 / Graphite	SPW S.S. 316 / Graphite
38	Washer	AISI 410	AISI 304	AISI 410	AISI 316
40	Disc Nut	AISI 304	AISI 304	AISI 304	AISI 316
48	Hinge Pin *	A182 Gr. F6a	A182 Gr. F304	A182 Gr. F6a	A 182 Gr. F316
50	Split Pin	AISI 304	AISI 304	AISI 304	AISI 316
57	Hinge	A 216 Gr.WCB / A 515 Gr.70	A 352 Gr. LCB	A 217 Gr. C5	A 351 Gr. CF8M
58	Hinge Bracket	A 216 Gr.WCB / A 515 Gr.70	A 352 Gr. LCB	A 217 Gr. C5	A 351 Gr. CF8M

(1) Zinc coating.

SLIGHTS

Body and Cover

Bodies and covers are high quality cast and afterwards precisely machined, directing the attention to prevent stress concentration.

The design characteristic of check valves is the unobstructed passageway, with a full-opening when required.

Body and Cover Gasket

The design of the body/cover gasket varies depending on the class of the valve.

Class 150 to 600 check valves consist of a male-female connection with a graphite or spiral wound gasket.

Class 900 and above check valves consist of a ring type joint.

In pressure seal designs the sealing is achieved through a gasket that takes advantage of the internal pressure of the line. The material most commonly used is high purity graphite being located between the body and the body retainer ring.

DESIGN STANDARDS

Bolted Bonnet Swing Check Valve	BS1868 & ASME B16.34 & API 6D
Pressure Seal Swing Check Valve (Long & Short pattern)	ASME B16.34
Face to Face / End to End Dimensions	ASME B16.10 / ISO 5752
End Flanged dimensions	ASME B16.5 / ISO 7005-1, ASME B16.47-A&B MSS SP- 44 & API 605
Butt-weld End dimensions	ASME B16.25
Valve inspection & testing	BS1868 & ISO 5208 & BS6755
Pressure - Temperature rating	ASME B16.34

TEST / INSPECTION METHODS & ACCEPTANCE CRITERIA

TEST / INSPECTION	METHOD	ACCEPTANCE CRITERIA
Visual Inspection		MSS SP-55
Marking		MSS SP-25 & ISO5208
Dimensional Inspection		Applicable valve
Chemical Analysis	ASTM E350	Applicable Standard
Mechanical Properties	ASTM A370	Applicable Standard
Liquid Penetrant Inspection	ASTM A165	ASME B16.34
Magnetic Particle Inspection	ASTM E709	ASME B16.34
Radiographic Inspection	ASME B16.34	ASME B16.34
Ultrasonic Inspection	ASTM A388	ASME B16.34
Pressure Testing	API 598 / ISO 5208	API 598 / ISO 5208

API 6D / BS 1868 BOLTED COVER

Class 150

VR150BC

Sizes 2" to 36"

TRIM

API 600 TRIM N°	Nominal TRIM	Stem / Backseat	Seating Surface Body / Wedge
1	F6	13Cr	13Cr
2	304	18Cr-8Ni	18Cr-8Ni
3	F310	25Cr-20Ni	25Cr-20Ni
4	Hard F6	13Cr	Hard 13Cr
5	Hardfaced	13Cr	Co-Cr A
5A	Hardfaced	13Cr	Ni-Cr
6	F6 and Cu-Ni	13Cr	13Cr and Cu-Ni
7	F6 and Hard F6	13Cr	13Cr and Hard 13Cr
8	F6 and Hardfaced	13Cr	13Cr and Co-Cr A
8A	F6 and Hardfaced	13Cr	13Cr and Ni-Cr
9	Monel	Ni-Cu Alloy	Ni-Cu Alloy
10	316	18Cr-8Ni-Mo	18Cr-8Ni-Mo
11	Monel and Hardfaced	Ni-Cu Alloy	Ni-Cu Alloy and Trim 5 or 5A
12	316 and Hardfaced	18Cr-8Ni-Mo	18Cr-8Ni-Mo and Trim 5 or 5A
13	Alloy 20	19Cr-29Ni	19Cr-29Ni
14	Alloy 20 and Hardfaced	19Cr-29Ni	19Cr-29Ni and Trim 5 or 5A
15	Hardfaced	18Cr-8Ni	Co-CrR A
16	Hardfaced	18Cr-8Ni-Mo	Co-CrR A
17	Hardfaced	18Cr-10Ni-Cb	Co-CrR A
18	Hardfaced	19Cr-29Ni	Co-CrR A

HF: Hard Facing using CoCr welding alloy (Stellite)

Materials

ACC. / ASME B16.34
 DI, WCB, WCC, WC1, WC6, WC9, C5, C12, LCB, LCC, CF8, CF8C, CF8M, CF3, CF3M,
 DUPLEX, SUPERDUPLEX, EXOTIC MATERIALS.

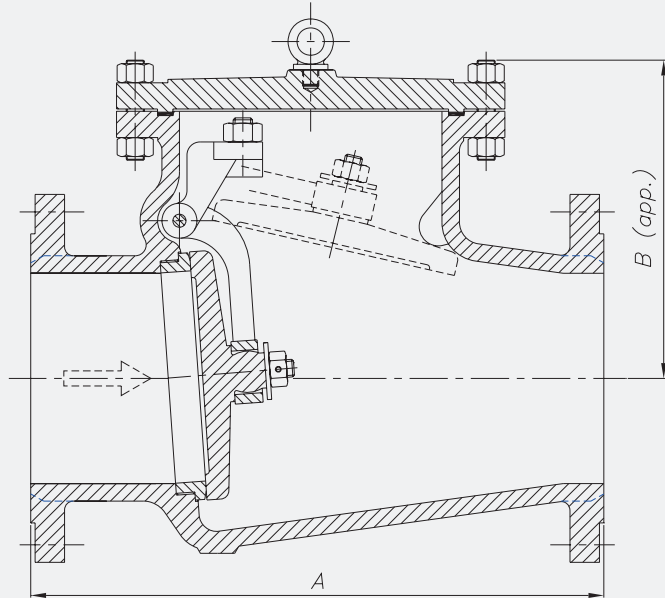

General dimensions

DN	A (RF / BW)	B	WEIGHT (App.)
50 (2")	203	135	17
65 (2½")	216	155	21
80 (3")	241	168	29
100 (4")	292	235	42
125 (5")	330	249	59
150 (6")	356	277	68
200 (8")	495	339	118
250 (10")	622	398	197
300 (12")	698	525	302
350 (14")	787	553	372
400 (16")	914	584	570
450 (18")	978	668	665
500 (20")	978	712	900
550 (22")	1067	725	1100
600 (24")	1295	740	1359
650 (26")	1295	780	1850
700 (28")	1448	810	2000
750 (30")	1524	1050	2400
900 (36")	1956	1390	3380

Dimensions in mm and weight in kg.
 Weights and dimensions can be changed without notice.
 Bigger sizes available under customer request.

API 6D / BS 1868 BOLTED COVER

Class 300

VR300BC

Sizes 2" to 20"

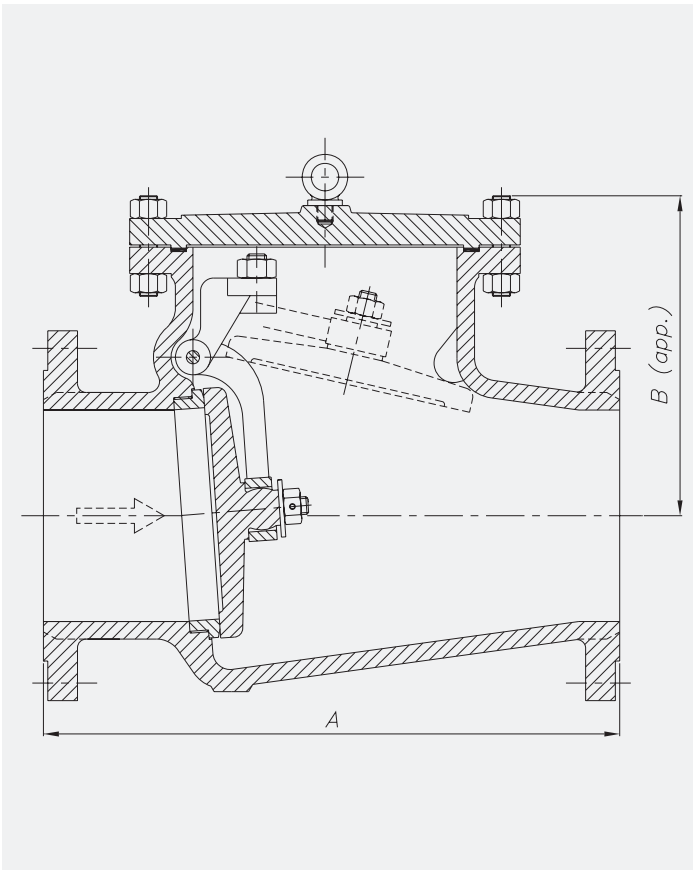

TRIM

API 600 TRIM N°	Nominal TRIM	Stem / Backseat	Seating Surface Body / Wedge
1	F6	13Cr	13Cr
2	304	18Cr-8Ni	18Cr-8Ni
3	F310	25Cr-20Ni	25Cr-20Ni
4	Hard F6	13Cr	Hard 13Cr
5	Hardfaced	13Cr	Co-Cr A
5A	Hardfaced	13Cr	Ni-Cr
6	F6 and Cu-Ni	13Cr	13Cr and Cu-Ni
7	F6 and Hard F6	13Cr	13Cr and Hard 13Cr
8	F6 and Hardfaced	13Cr	13Cr and Co-Cr A
8A	F6 and Hardfaced	13Cr	13Cr and Ni-Cr
9	Monel	Ni-Cu Alloy	Ni-Cu Alloy
10	316	18Cr-8Ni-Mo	18Cr-8Ni-Mo
11	Monel and Hardfaced	Ni-Cu Alloy	Ni-Cu Alloy and Trim 5 or 5A
12	316 and Hardfaced	18Cr-8Ni-Mo	18Cr-8Ni-Mo and Trim 5 or 5A
13	Alloy 20	19Cr-29Ni	19Cr-29Ni
14	Alloy 20 and Hardfaced	19Cr-29Ni	19Cr-29Ni and Trim 5 or 5A
15	Hardfaced	18Cr-8Ni	Co-Cr A
16	Hardfaced	18Cr-8Ni-Mo	Co-Cr A
17	Hardfaced	18Cr-10Ni-Cb	Co-Cr A
18	Hardfaced	19Cr-29Ni	Co-Cr A

HF: Hard Facing using CoCr welding alloy (Stellite)

Materials

ACC. / ASME B16.34
 DI, WCB, WCC, WC1, WC6, WC9, C5, C12, LCB, LCC, CF8, CF8C, CF8M, CF3, CF3M,
 DUPLEX, SUPERDUPLEX, EXOTIC MATERIALS.

General dimensions

DN	A (RF / BW)	B	WEIGHT (App.)
50 (2")	267	158	21
65 (2½")	292	167	35
80 (3")	318	188	43
100 (4")	356	259	60
125 (5")	400	281	85
150 (6")	444	319	131
200 (8")	533	401	213
250 (10")	622	483	384
300 (12")	711	555	449
350 (14")	838	585	680
400 (16")	864	615	840
450 (18")	978	643	1025
500 (20")	1016	681	1180

Dimensions in mm and weight in kg.
 Weights and dimensions can be changed without notice.
 Bigger sizes available under customer request.

API 6D / BS 1868 BOLTED COVER

Class 600

VR600BC

Sizes 2" to 16"

TRIM

API 600 TRIM N°	Nominal TRIM	Stem / Backseat	Seating Surface Body / Wedge
1	F6	13Cr	13Cr
2	304	18Cr-8Ni	18Cr-8Ni
3	F310	25Cr-20Ni	25Cr-20Ni
4	Hard F6	13Cr	Hard 13Cr
5	Hardfaced	13Cr	Co-Cr A
5A	Hardfaced	13Cr	Ni-Cr
6	F6 and Cu-Ni	13Cr	13Cr and Cu-Ni
7	F6 and Hard F6	13Cr	13Cr and Hard 13Cr
8	F6 and Hardfaced	13Cr	13Cr and Co-Cr A
8A	F6 and Hardfaced	13Cr	13Cr and Ni-Cr
9	Monel	Ni-Cu Alloy	Ni-Cu Alloy
10	316	18Cr-8Ni-Mo	18Cr-8Ni-Mo
11	Monel and Hardfaced	Ni-Cu Alloy	Ni-Cu Alloy and Trim 5 or 5A
12	316 and Hardfaced	18Cr-8Ni-Mo	18Cr-8Ni-Mo and Trim 5 or 5A
13	Alloy 20	19Cr-29Ni	19Cr-29Ni
14	Alloy 20 and Hardfaced	19Cr-29Ni	19Cr-29Ni and Trim 5 or 5A
15	Hardfaced	18Cr-8Ni	Co-CRr A
16	Hardfaced	18Cr-8Ni-Mo	Co-CRr A
17	Hardfaced	18Cr-10Ni-Cb	Co-CRr A
18	Hardfaced	19Cr-29Ni	Co-CRr A

HF: Hard Facing using CoCr welding alloy (Stellite)

Materials

ACC. / ASME B16.34
 DI, WCB, WCC, WC1, WC6, WC9, C5, C12, LCB, LCC, CF8, CF8C, CF8M, CF3, CF3M,
 DUPLEX, SUPERDUPLEX, EXOTIC MATERIALS.

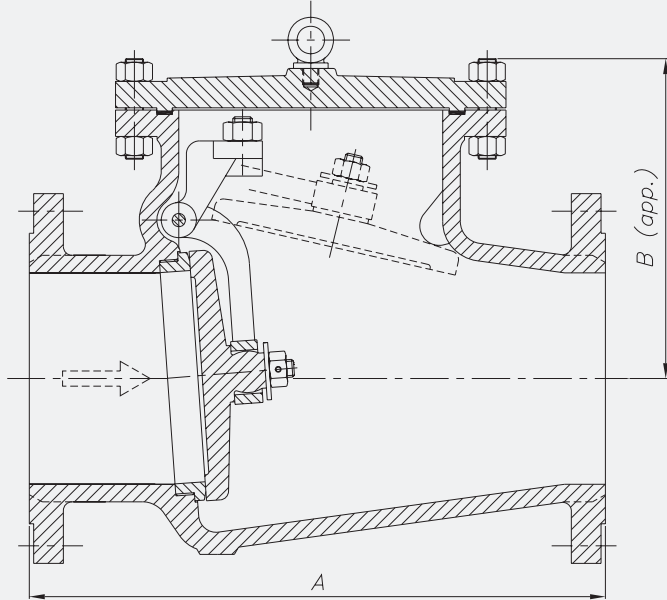

General dimensions

DN	A (RF / BW)	B	WEIGHT (App.)
50 (2")	292	197	26
65 (2½")	330	207	45
80 (3")	356	231	68
100 (4")	432	281	90
125 (5")	508	319	140
150 (6")	559	362	200
200 (8")	660	437	360
250 (10")	787	490	673
300 (12")	838	528	875
350 (14")	889	572	944
400 (16")	991	660	1220

Dimensions in mm and weight in kg.
 Weights and dimensions can be changed without notice.
 Bigger sizes available under customer request.

API 6D / BS 1868 BOLTED COVER

Class 900

VR900BC

Sizes 2" to 8"

TRIM

API 600 TRIM N°	Nominal TRIM	Stem / Backseat	Seating Surface Body / Wedge
1	F6	13Cr	13Cr
2	304	18Cr-8Ni	18Cr-8Ni
3	F310	25Cr-20Ni	25Cr-20Ni
4	Hard F6	13Cr	Hard 13Cr
5	Hardfaced	13Cr	Co-Cr A
5A	Hardfaced	13Cr	Ni-Cr
6	F6 and Cu-Ni	13Cr	13Cr and Cu-Ni
7	F6 and Hard F6	13Cr	13Cr and Hard 13Cr
8	F6 and Hardfaced	13Cr	13Cr and Co-Cr A
8A	F6 and Hardfaced	13Cr	13Cr and Ni-Cr
9	Monel	Ni-Cu Alloy	Ni-Cu Alloy
10	316	18Cr-8Ni-Mo	18Cr-8Ni-Mo
11	Monel and Hardfaced	Ni-Cu Alloy	Ni-Cu Alloy and Trim 5 or 5A
12	316 and Hardfaced	18Cr-8Ni-Mo	18Cr-8Ni-Mo and Trim 5 or 5A
13	Alloy 20	19Cr-29Ni	19Cr-29Ni
14	Alloy 20 and Hardfaced	19Cr-29Ni	19Cr-29Ni and Trim 5 or 5A
15	Hardfaced	18Cr-8Ni	Co-Cr A
16	Hardfaced	18Cr-8Ni-Mo	Co-Cr A
17	Hardfaced	18Cr-10Ni-Cb	Co-Cr A
18	Hardfaced	19Cr-29Ni	Co-Cr A

HF: Hard Facing using CoCr welding alloy (Stellite)

Materials

ACC. / ASME B16.34
 DI, WCB, WCC, WC1, WC6, WC9, C5, C12, LCB, LCC, CF8, CF8C, CF8M, CF3, CF3M,
 DUPLEX, SUPERDUPLEX, EXOTIC MATERIALS.

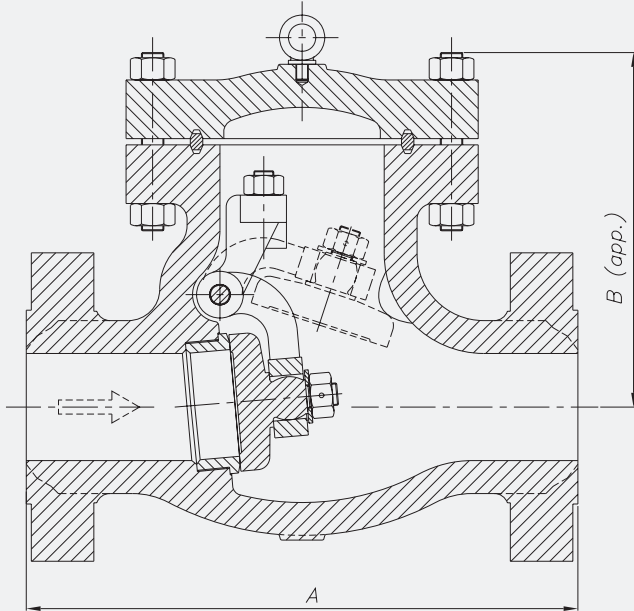

General dimensions

DN	A (RF / BW)	B	WEIGHT (App.)
50 (2")	368	240	76
65 (2½")	419	250	86
80 (3")	381	260	98
100 (4")	457	320	145
125 (5")	559	350	175
150 (6")	610	382	259
200 (8")	737	530	565

Dimensions in mm and weight in kg.
 Weights and dimensions can be changed without notice.
 Bigger sizes available under customer request.

API 6D / BS 1868 BOLTED COVER

Class 1500

VR1500BC

Sizes 2" to 8"

TRIM

API 600 TRIM N°	Nominal TRIM	Stem / Backseat	Seating Surface Body / Wedge
1	F6	13Cr	13Cr
2	304	18Cr-8Ni	18Cr-8Ni
3	F310	25Cr-20Ni	25Cr-20Ni
4	Hard F6	13Cr	Hard 13Cr
5	Hardfaced	13Cr	Co-Cr A
5A	Hardfaced	13Cr	Ni-Cr
6	F6 and Cu-Ni	13Cr	13Cr and Cu-Ni
7	F6 and Hard F6	13Cr	13Cr and Hard 13Cr
8	F6 and Hardfaced	13Cr	13Cr and Co-Cr A
8A	F6 and Hardfaced	13Cr	13Cr and Ni-Cr
9	Monel	Ni-Cu Alloy	Ni-Cu Alloy
10	316	18Cr-8Ni-Mo	18Cr-8Ni-Mo
11	Monel and Hardfaced	Ni-Cu Alloy	Ni-Cu Alloy and Trim 5 or 5A
12	316 and Hardfaced	18Cr-8Ni-Mo	18Cr-8Ni-Mo and Trim 5 or 5A
13	Alloy 20	19Cr-29Ni	19Cr-29Ni
14	Alloy 20 and Hardfaced	19Cr-29Ni	19Cr-29Ni and Trim 5 or 5A
15	Hardfaced	18Cr-8Ni	Co-CrR A
16	Hardfaced	18Cr-8Ni-Mo	Co-CrR A
17	Hardfaced	18Cr-10Ni-Cb	Co-CrR A
18	Hardfaced	19Cr-29Ni	Co-CrR A

HF: Hard Facing using CoCr welding alloy (Stellite)

Materials

ACC. / ASME B16.34
 DI, WCB, WCC, WC1, WC6, WC9, C5, C12, LCB, LCC, CF8, CF8C, CF8M, CF3, CF3M,
 DUPLEX, SUPERDUPLEX, EXOTIC MATERIALS.

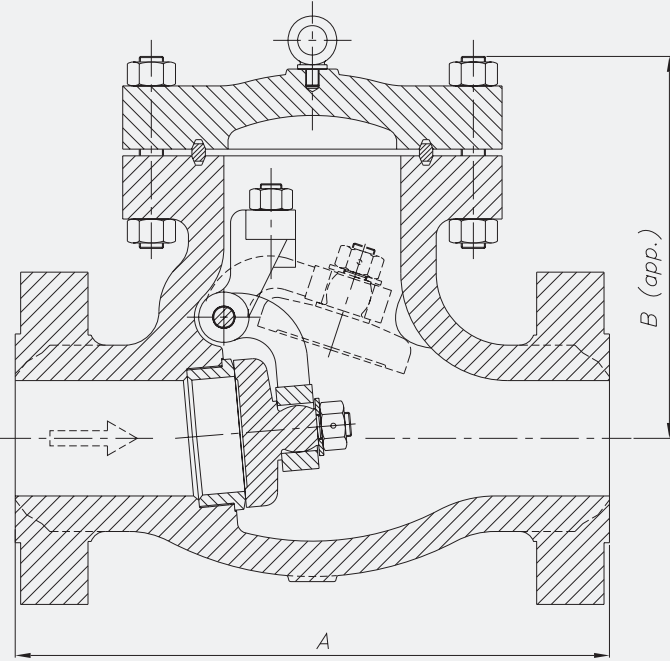

General dimensions

DN	A (RF / BW)	B	WEIGHT (App.)
50 (2")	368	265	76
65 (2½")	419	275	93
80 (3")	470	290	140
100 (4")	546	385	232
125 (5")	673	430	362
150 (6")	705	470	490
200 (8")	832	625	990

Dimensions in mm and weight in kg.
 Weights and dimensions can be changed without notice.
 Bigger sizes available under customer request.

API 6D / BS 1868 BOLTED COVER

Class 2500

VR2500BC

Sizes 2" to 8"

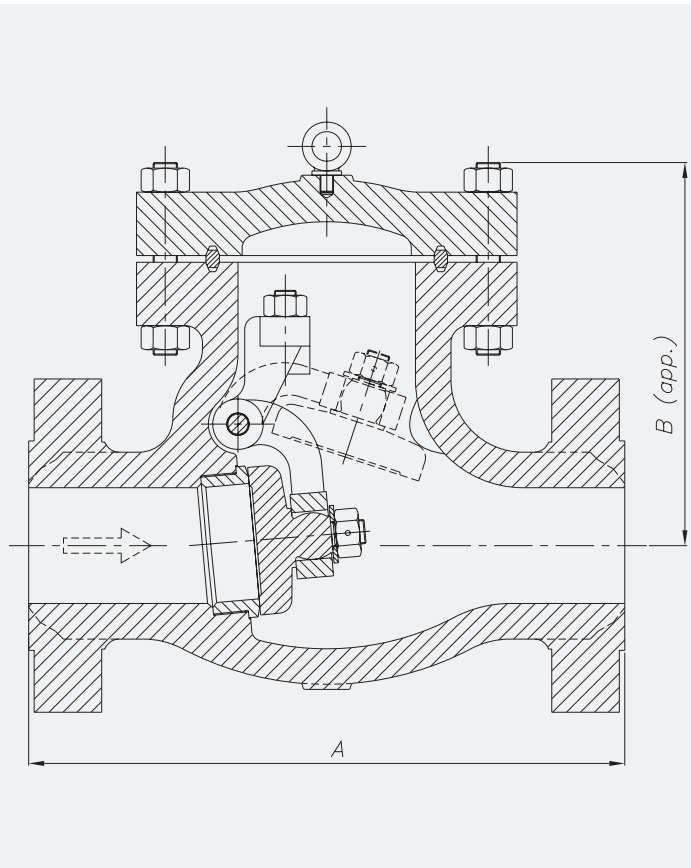

TRIM

API 600 TRIM N°	Nominal TRIM	Stem / Backseat	Seating Surface Body / Wedge
1	F6	13Cr	13Cr
2	304	18Cr-8Ni	18Cr-8Ni
3	F310	25Cr-20Ni	25Cr-20Ni
4	Hard F6	13Cr	Hard 13Cr
5	Hardfaced	13Cr	Co-Cr A
5A	Hardfaced	13Cr	Ni-Cr
6	F6 and Cu-Ni	13Cr	13Cr and Cu-Ni
7	F6 and Hard F6	13Cr	13Cr and Hard 13Cr
8	F6 and Hardfaced	13Cr	13Cr and Co-Cr A
8A	F6 and Hardfaced	13Cr	13Cr and Ni-Cr
9	Monel	Ni-Cu Alloy	Ni-Cu Alloy
10	316	18Cr-8Ni-Mo	18Cr-8Ni-Mo
11	Monel and Hardfaced	Ni-Cu Alloy	Ni-Cu Alloy and Trim 5 or 5A
12	316 and Hardfaced	18Cr-8Ni-Mo	18Cr-8Ni-Mo and Trim 5 or 5A
13	Alloy 20	19Cr-29Ni	19Cr-29Ni
14	Alloy 20 and Hardfaced	19Cr-29Ni	19Cr-29Ni and Trim 5 or 5A
15	Hardfaced	18Cr-8Ni	Co-Cr A
16	Hardfaced	18Cr-8Ni-Mo	Co-Cr A
17	Hardfaced	18Cr-10Ni-Cb	Co-Cr A
18	Hardfaced	19Cr-29Ni	Co-Cr A

HF: Hard Facing using CoCr welding alloy (Stellite)

Materials

ACC. / ASME B16.34
 DI, WCB, WCC, WC1, WC6, WC9, C5, C12, LCB, LCC, CF8, CF8C, CF8M, CF3, CF3M,
 DUPLEX, SUPERDUPLEX, EXOTIC MATERIALS.

General dimensions

DN	A (RF / BW)	B	WEIGHT (App.)
50 (2")	451	315	100
65 (2½")	508	345	185
80 (3")	578	380	225
100 (4")	673	410	370
125 (5")	794	495	595
150 (6")	914	560	805
200 (8")	1022	695	1320

Dimensions in mm and weight in kg.
 Weights and dimensions can be changed without notice.
 Bigger sizes available under customer request.

| GATE, GLOBE & CHECK VALVES |

CHECK VALVES

PRESSURE SEAL

2" - 20" | Class 900 - Class 2500

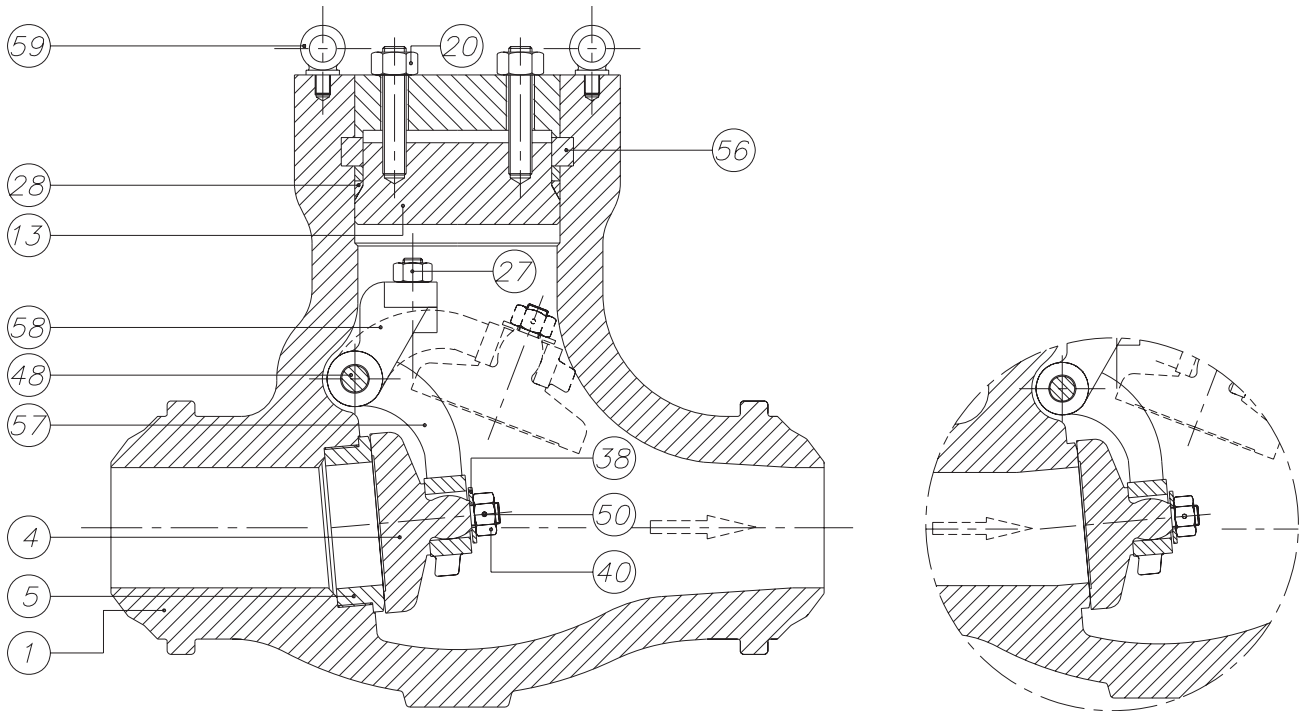

Stainless steel construction.

BILL OF MATERIALS		TRIM 8	TRIM 2	TRIM 8	TRIM 10
Item	Description	Carbon Steel	Carbon Steel (Low Temp.)	Alloy Steel	Stainless Steel
1	Body	A 216 Gr. WCB	A 352 Gr. LCB	A 217 Gr. C5	A 351 Gr. CF8M
4	Disc	A105 + ER 410	A 182 Gr. F304	A 182 Gr. F6a	A 182 Gr. F316
5	Seat Ring	A105 + Stellite	A 182 Gr. F304	A 182 Gr. F6a + Stellite	----
13	Cover	A 216 Gr. WCB / A 515 Gr. 70	A 352 Gr. LCB / A 182 Gr. F304	A 217 Gr. C5	A 351 Gr. CF8M
20	Cover Bolt & Nut	A 193 Gr. B7 / A 194 Gr. 2H	A 320 Gr. L7 / A 194 Gr. 7	A 193 Gr. B7 / A 194 Gr. 2H	A 193 Gr. B7 / A 194 Gr. 2H ⁽¹⁾
27	Bracket Stud & Nut	A 193 Gr. B8 / A 194 Gr. 8	A 193 Gr. B8 / A 194 Gr. 8	A 193 Gr. B8 / A 194 Gr. 8	A 193 Gr. B8M / A 194 Gr. 8M
28	Gasket	SS304L or Graphite	SS304L or Graphite	SS304L or Graphite	SS316L or Graphite
38	Washer	AISI 410	AISI 304	AISI 410	AISI 316
40	Disc Nut	AISI 304	AISI 304	AISI 304	AISI 316
48	Hinge Pin *	A182 Gr. F6a	A182 Gr. F304	A182 Gr. F6a	A 182 Gr. F316
50	Split Pin	AISI 304	AISI 304	AISI 304	AISI 316
57	Hinge	A 216 Gr. WCB / A 515 Gr. 70	A 352 Gr. LCB	A 217 Gr. C5	A 351 Gr. CF8M
58	Hinge Bracket	A 216 Gr. WCB / A 515 Gr. 70	A 352 Gr. LCB	A 217 Gr. C5	A 351 Gr. CF8M
59	Lifting Hook	A105	A105	A105	A105

Item 5 only in Carbon Steel and Alloy Steel construction.
 * It's also manufactured with Hinge Pin Passing through Body with Plug.
⁽¹⁾ Zinc coating.

ASME B16.34 PRESSURE SEAL

Class 900

VR900PS

Sizes 2" to 16"

TRIM

API 600 TRIM N°	Nominal TRIM	Stem / Backseat	Seating Surface Body / Wedge
1	F6	13Cr	13Cr
2	304	18Cr-8Ni	18Cr-8Ni
3	F310	25Cr-20Ni	25Cr-20Ni
4	Hard F6	13Cr	Hard 13Cr
5	Hardfaced	13Cr	Co-Cr A
5A	Hardfaced	13Cr	Ni-Cr
6	F6 and Cu-Ni	13Cr	13Cr and Cu-Ni
7	F6 and Hard F6	13Cr	13Cr and Hard 13Cr
8	F6 and Hardfaced	13Cr	13Cr and Co-Cr A
8A	F6 and Hardfaced	13Cr	13Cr and Ni-Cr
9	Monel	Ni-Cu Alloy	Ni-Cu Alloy
10	316	18Cr-8Ni-Mo	18Cr-8Ni-Mo
11	Monel and Hardfaced	Ni-Cu Alloy	Ni-Cu Alloy and Trim 5 or 5A
12	316 and Hardfaced	18Cr-8Ni-Mo	18Cr-8Ni-Mo and Trim 5 or 5A
13	Alloy 20	19Cr-29Ni	19Cr-29Ni
14	Alloy 20 and Hardfaced	19Cr-29Ni	19Cr-29Ni and Trim 5 or 5A
15	Hardfaced	18Cr-8Ni	Co-Cr A
16	Hardfaced	18Cr-8Ni-Mo	Co-Cr A
17	Hardfaced	18Cr-10Ni-Cb	Co-Cr A
18	Hardfaced	19Cr-29Ni	Co-Cr A

HF: Hard Facing using CoCr welding alloy (Stellite)

Materials

ACC. / ASME B16.34
 DI, WCB, WCC, WC1, WC6, WC9, C5, C12, LCB, LCC, CF8, CF8C, CF8M, CF3, CF3M,
 DUPLEX, SUPERDUPLEX, EXOTIC MATERIALS.

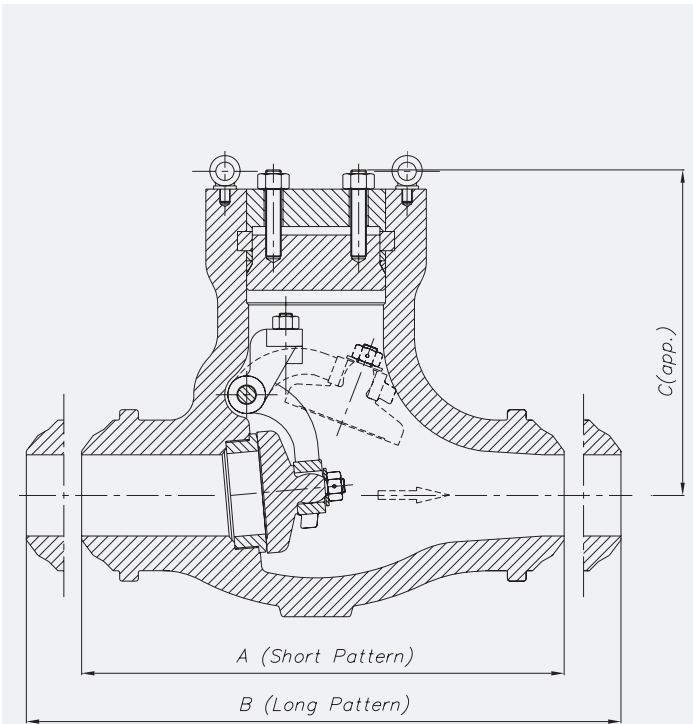

* Long pattern available with flanges.

General dimensions

DN	A	B	ØC	WEIGHT (App.) ⁽¹⁾
50 (2")	216	368	255	40
65 (2½")	254	419	275	55
80 (3")	305	381	295	70
100 (4")	356	457	335	95
125 (5")	432	559	395	125
150 (6")	508	610	435	195
200 (8")	660	737	530	290
250 (10")	787	838	605	425
300 (12")	914	965	700	680
350 (14")	991	1029	805	975
400 (16")	1092	1130	925	1405

⁽¹⁾ BW ends, short pattern.

Dimensions in mm and weight in kg.

Weights and dimensions can be changed without notice.

Bigger sizes available under customer request.

ASME B16.34 PRESSURE SEAL

Class 1500

VR1500PS

Sizes 2" to 16"

TRIM

API 600 TRIM N°	Nominal TRIM	Stem / Backseat	Seating Surface Body / Wedge
1	F6	13Cr	13Cr
2	304	18Cr-8Ni	18Cr-8Ni
3	F310	25Cr-20Ni	25Cr-20Ni
4	Hard F6	13Cr	Hard 13Cr
5	Hardfaced	13Cr	Co-Cr A
5A	Hardfaced	13Cr	Ni-Cr
6	F6 and Cu-Ni	13Cr	13Cr and Cu-Ni
7	F6 and Hard F6	13Cr	13Cr and Hard 13Cr
8	F6 and Hardfaced	13Cr	13Cr and Co-Cr A
8A	F6 and Hardfaced	13Cr	13Cr and Ni-Cr
9	Monel	Ni-Cu Alloy	Ni-Cu Alloy
10	316	18Cr-8Ni-Mo	18Cr-8Ni-Mo
11	Monel and Hardfaced	Ni-Cu Alloy	Ni-Cu Alloy and Trim 5 or 5A
12	316 and Hardfaced	18Cr-8Ni-Mo	18Cr-8Ni-Mo and Trim 5 or 5A
13	Alloy 20	19Cr-29Ni	19Cr-29Ni
14	Alloy 20 and Hardfaced	19Cr-29Ni	19Cr-29Ni and Trim 5 or 5A
15	Hardfaced	18Cr-8Ni	Co-CrR A
16	Hardfaced	18Cr-8Ni-Mo	Co-CrR A
17	Hardfaced	18Cr-10Ni-Cb	Co-CrR A
18	Hardfaced	19Cr-29Ni	Co-CrR A

HF: Hard Facing using CoCr welding alloy (Stellite)

Materials

ACC. / ASME B16.34
 DI, WCB, WCC, WC1, WC6, WC9, C5, C12, LCB, LCC, CF8, CF8C, CF8M, CF3, CF3M,
 DUPLEX, SUPERDUPLEX, EXOTIC MATERIALS.

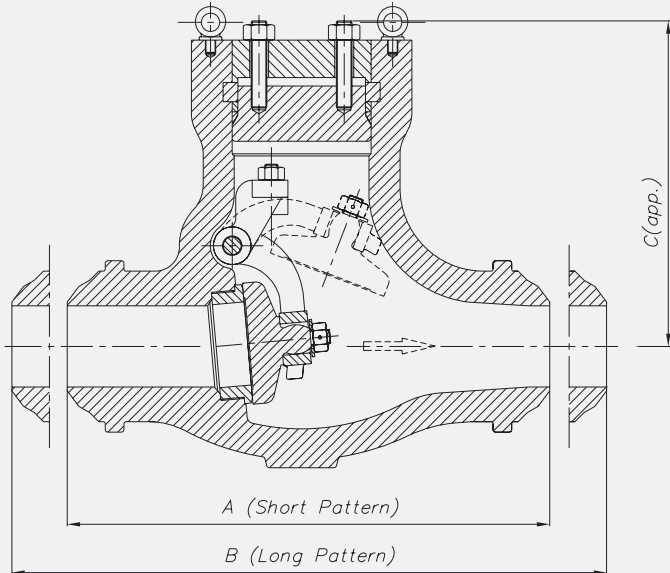

* Long pattern available with flanges.

General dimensions

DN	A	B	ØC	WEIGHT (App.) ^(*)
50 (2")	216	368	310	45
65 (2½")	254	419	310	65
80 (3")	305	470	330	80
100 (4")	406	546	355	140
125 (5")	483	673	380	205
150 (6")	559	705	400	407
200 (8")	711	832	530	605
250 (10")	864	991	560	1091
300 (12")	991	1130	650	1369
350 (14")	1067	1257	770	2015
400 (16")	1194	1384	915	2520

^(*) BW ends, short pattern.
 Dimensions in mm and weight in kg.
 Weights and dimensions can be changed without notice.
 Bigger sizes available under customer request.

ASME B16.34 PRESSURE SEAL

Class 2500

VR2500PS

Sizes 2" to 12"

TRIM

API 600 TRIM N°	Nominal TRIM	Stem / Backseat	Seating Surface Body / Wedge
1	F6	13Cr	13Cr
2	304	18Cr-8Ni	18Cr-8Ni
3	F310	25Cr-20Ni	25Cr-20Ni
4	Hard F6	13Cr	Hard 13Cr
5	Hardfaced	13Cr	Co-Cr A
5A	Hardfaced	13Cr	Ni-Cr
6	F6 and Cu-Ni	13Cr	13Cr and Cu-Ni
7	F6 and Hard F6	13Cr	13Cr and Hard 13Cr
8	F6 and Hardfaced	13Cr	13Cr and Co-Cr A
8A	F6 and Hardfaced	13Cr	13Cr and Ni-Cr
9	Monel	Ni-Cu Alloy	Ni-Cu Alloy
10	316	18Cr-8Ni-Mo	18Cr-8Ni-Mo
11	Monel and Hardfaced	Ni-Cu Alloy	Ni-Cu Alloy and Trim 5 or 5A
12	316 and Hardfaced	18Cr-8Ni-Mo	18Cr-8Ni-Mo and Trim 5 or 5A
13	Alloy 20	19Cr-29Ni	19Cr-29Ni
14	Alloy 20 and Hardfaced	19Cr-29Ni	19Cr-29Ni and Trim 5 or 5A
15	Hardfaced	18Cr-8Ni	Co-Cr A
16	Hardfaced	18Cr-8Ni-Mo	Co-Cr A
17	Hardfaced	18Cr-10Ni-Cb	Co-Cr A
18	Hardfaced	19Cr-29Ni	Co-Cr A

HF: Hard Facing using CoCr welding alloy (Stellite)

Materials

ACC. / ASME B16.34
 DI, WCB, WCC, WC1, WC6, WC9, C5, C12, LCB, LCC, CF8, CF8C, CF8M, CF3, CF3M,
 DUPLEX, SUPERDUPLEX, EXOTIC MATERIALS.

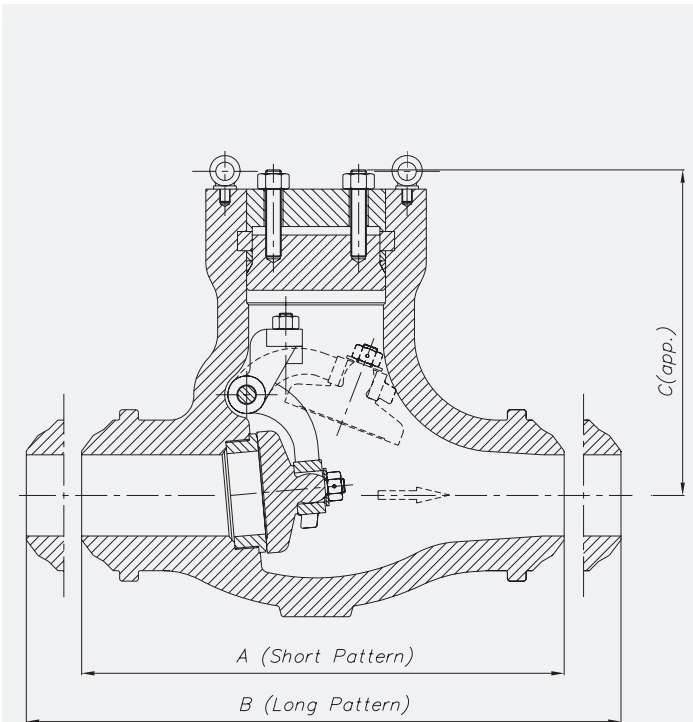

* Long pattern available with flanges.

General dimensions

DN	A	B	ØC	WEIGHT (App.) ⁽¹⁾
50 (2")	279	451	335	75
65 (2½")	330	508	350	95
80 (3")	368	578	390	120
100 (4")	457	673	435	165
125 (5")	533	794	505	245
150 (6")	610	914	570	425
200 (8")	762	1022	855	665
250 (10")	914	1270	945	1190
300 (12")	1041	1422	1015	1555

⁽¹⁾ BW ends, short pattern.

Dimensions in mm and weight in kg.

Weights and dimensions can be changed without notice.

Bigger sizes available under customer request.

END FLANGE DIMENSIONS (Raised Face)

CLASS 150, 300 & 600

SIZE	ID		D		E		F		G		H		N° of Holes																											
	inch.	mm.	inch.	mm.	inch.	mm.	inch.	mm.	inch.	mm.	inch.	mm.																												
														CLASS 150														2"	51	6	152,4	4,75	120,7	3,62	91,9	0,62	15,7	0,75	19,0	4
																												3"	76	7,50	190,5	6	152,4	5	127,0	0,75	19,1	0,75	19,0	4
4"	102	9	228,6	7,5	190,5	6,19	157,2	0,94	23,9	0,75	19,0	8																												
6"	152	11	279,4	9,5	241,3	8,5	215,9	1	25,4	0,88	22,5	8																												
8"	203	13,5	342,9	11,75	298,5	10,62	269,7	1,12	28,4	0,88	22,5	8																												
10"	254	16	406,4	14,25	362,0	12,75	323,9	1,19	30,2	1	25,5	12																												
12"	305	19	482,6	17	431,8	15	381,0	1,25	31,8	1	25,5	12																												
14"	337	21	533,4	18,75	476,3	16,25	412,8	1,38	35,1	1,12		12																												
16"	387	23,5	596,9	21,25	539,8	18,5	469,9	1,44	36,6	1,12	28,5	16																												
18"	438	25	635,0	22,75	577,9	21	533,4	1,56	39,6	1,25	32,0	16																												
20"	489	27,5	698,5	25	635,0	23	584,2	1,69	42,9	1,25	32,0	20																												
24"	591	32	812,8	29,5	749,3	27,25	692,2	1,88	47,8	1,38	35,0	20																												
30"	743	38,75	984,3	36	914,4	33,75	857,3	2,94	74,7	1,38	35,0	28																												
36"	878	46	1168,4	42,75	1085,9	40,25	1022,4	3,56	90,4	1,62	41,5	32																												
42"	1025	53	1346,2	49,5	1257,3	47	1193,8	3,81	96,8	1,62	41,5	36																												
48"	1169	59,5	1511,3	56	1422,4	53,5	1358,9	4,25	108,0	1,62	41,5	44																												
30"	743	34,94	887,5	33,31	846,1	32	812,8	1,75	44,5	0,88	22,5	44																												
36"	878	41,62	1057,1	39,75	1009,7	38,25	971,6	2,06	52,3	1	25,5	44																												
42"	1025	48,25	1225,6	46,12	1171,4	44,5	1130,3	2,31	58,7	1,12	28,5	48																												
48"	1169	54,81	1392,2	52,56	1335,0	50,75	1289,1	2,56	65,0	1,25	32,0	44																												
CLASS 300														2"	51	6,5	165,1	5	127,0	3,62	91,9	0,88	22,4	0,75	19,0	8														
														3"	76	8,25	209,6	6,62	168,1	5	127,0	1,12	28,4	0,88	22,5	8														
														4"	102	10	254,0	7,88	200,2	6,19	157,2	1,25	31,8	0,88	22,5	8														
														6"	152	12,5	317,5	10,62	269,7	8,5	215,9	1,44	36,6	0,88	22,5	12														
														8"	203	15	381,0	13	330,2	10,62	269,7	1,62	41,1	1	25,5	12														
														10"	254	17,5	444,5	15,25	387,4	12,75	323,9	1,88	47,8	1,12	28,5	16														
														12"	305	20,5	520,7	17,75	450,9	15	381,0	2	50,8	1,25	32,0	16														
														14"	337	23	584,2	20,25	514,4	16,25	412,8	2,12	53,8	1,25	32,0	20														
														16"	387	25,5	647,7	22,5	571,5	18,5	469,9	2,25	57,2	1,38	35,0	20														
														18"	432	28	711,2	24,75	628,7	21	533,4	2,38	60,5	1,38	35,0	24														
														20"	483	30,5	774,7	27	685,8	23	584,2	2,5	63,5	1,38	35,0	24														
														24"	584	36	914,4	32	812,8	27,25	692,2	2,75	69,9	1,62	41,5	24														
														30"	737	43	1092,2	39,25	997,0	33,75	857,3	3,62	91,9	1,88	48,0	28														
														36"	890	50	1270,0	46	1168,4	40,25	1022,4	4,12	104,6	2,12	54,0	32														
														42"	1016	50,75	1289,1	47,5	1206,5	44,75	1136,7	4,69	119,1	1,75	44,5	32														
														30"	737	39	990,6	36,25	920,8	33,25	844,6	3,69	93,7	1,5	38,5	36														
														36"	890	46,12	1171,4	42,88	1089,2	39,75	1009,7	4,06	103,1	1,75	44,5	32														
														42"	1016	52,5	1333,5	49	1244,6	46	1168,4	4,69	119,1	1,88	48,0	36														
CLASS 600														2"	51	6,5	165,1	5	127,0	3,62	91,9	1	25,4	0,75	19,0	8														
														3"	76	8,25	209,6	6,62	168,1	5	127,0	1,25	31,8	0,88	22,5	8														
														4"	102	10,75	273,1	8,5	215,9	6,19	157,2	1,5	38,1	1	25,5	8														
														6"	152	14	355,6	11,5	292,1	8,5	215,9	1,88	47,8	1,12	28,5	12														
														8"	200	16,5	419,1	13,75	349,3	10,62	269,7	2,19	55,6	1,25	32,0	12														
														10"	248	20	508,0	17	431,8	12,75	323,9	2,5	63,5	1,38	35,0	16														
														12"	298	22	558,8	19,25	489,0	15	381,0	2,62	66,5	1,38	35,0	20														
														14"	327	23,75	603,3	20,75	527,1	16,25	412,8	2,75	69,9	1,5	38,5	20														
														16"	375	27	685,8	23,75	603,3	18,5	469,9	3	76,2	1,62	41,5	20														
														18"	419	29,25	743,0	25,75	654,1	21	533,4	3,25	82,6	1,75	44,5	20														
														20"	464	32	812,8	28,5	723,9	23	584,2	3,5	88,9	1,75	44,5	24														
														24"	559	37	939,8	33	838,2	27,25	692,2	4	101,6	2	51,0	24														
														30"	695	44,5	1130,3	40,25	1022,4	33,75	857,3	4,5	114,3	2,12	54,0	28														
														36"	865	51,75	1314,5	47	1193,8	40,25	1022,4	4,88	124,0	2,62	66,5	28														
														42"	992	55,25	1403,4	50,5	1282,7	46	1168,4	6,62	168,1	2,62	66,5	28														
														30"	695	40,25	1022,4	36,5	927,1	33,12	841,2	4,94	125,5	2	51,0	28														
														36"	865	47,75	1212,9	43,5	1104,9	39,75	1009,7	5,75	146,1	2,38	60,5	28														
														42"	992	55,25	1403,4	50,5	1282,7	46	1168,4	6,62	168,1	2,62	66,5	28														

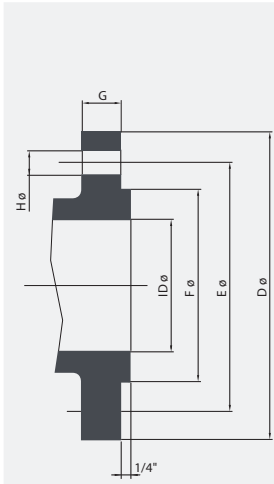
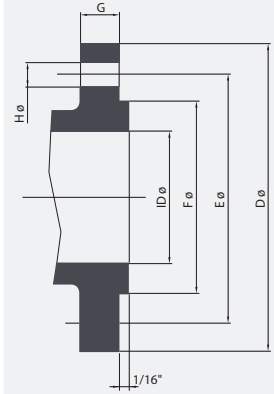

END FLANGE DIMENSIONS (Raised Face)

CLASS 900, 1500 & 2500

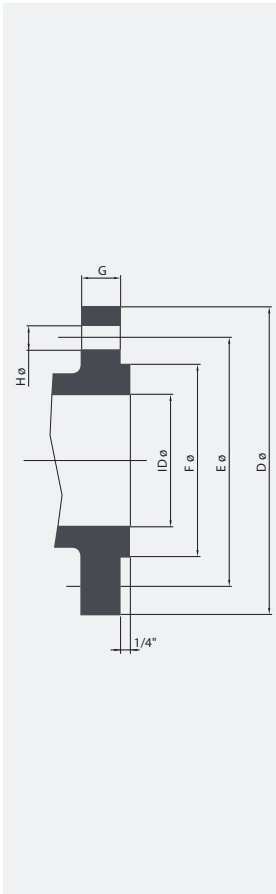

SIZE	ID	D		E		F		G		H		N° of Holes
		inch.	mm.	inch.	mm.	inch.	mm.	inch.	mm.	inch.	mm.	
CLASS 900												
2"	48	8,5	215,9	6,5	165,1	3,62	91,9	1,5	38,1	1	25,5	8
3"	73	9,5	241,3	7,5	190,5	5	127,0	1,5	38,1	1	25,5	8
4"	99	11,5	292,1	9,25	235,0	6,19	157,2	1,75	44,5	1,25	32,0	8
6"	146	15	381,0	12,5	317,5	8,5	215,9	2,19	55,6	1,25	32,0	12
8"	191	18,5	469,9	15,5	393,7	10,62	269,7	2,5	63,5	1,5	38,5	12
10"	238	21,5	546,1	18,5	469,9	12,75	323,9	2,75	69,9	1,5	38,5	16
12"	283	24	609,6	21	533,4	15	381,0	3,12	79,2	1,5	38,5	20
14"	311	25,25	641,4	22	558,8	16,25	412,8	3,38	85,9	1,62	41,5	20
16"	356	27,75	704,9	24,25	616,0	18,5	469,9	3,5	88,9	1,75	44,5	20
18"	400	31	787,4	27	685,8	21	533,4	4	101,6	2	51,0	20
20"	445	33,75	857,3	29,5	749,3	23	584,2	4,25	108,0	2,12	54,0	20
CLASS 1500												
2"	48	8,5	215,9	6,5	165,1	3,62	91,9	1,5	38,1	1	25,5	8
3"	70	10,5	266,7	8	203,2	5	127,0	1,88	47,8	1,25	32,0	8
4"	92	12,25	311,2	9,5	241,3	6,19	157,2	2,12	53,8	1,38	35,0	8
6"	137	15,5	393,7	12,5	317,5	8,5	215,9	3,25	82,6	1,5	38,5	12
8"	178	19	482,6	15,5	393,7	10,62	269,7	3,62	91,9	1,75	44,5	12
10"	223	23	584,2	19	482,6	12,75	323,9	4,25	108,0	2	51,0	12
12"	264	26,5	673,1	22,5	571,5	15	381,0	4,88	124,0	2,12	54,0	16
14"	289	29,5	749,3	25	635,0	16,25	412,8	5,25	133,4	2,38	60,5	16
16"	331	32,5	825,5	27,75	704,9	18,5	469,9	5,75	146,1	2,62	66,5	16
18"	372	36	914,4	30,5	774,7	21	533,4	6,38	162,1	2,88	73,0	16
CLASS 2500												
2"	38	9,25	235,0	6,75	171,5	3,62	91,9	2	50,8	1,12	28,5	8
3"	57	12	304,8	9	228,6	5	127,0	2,62	66,5	1,38	35,0	8
4"	73	14	355,6	10,75	273,1	6,19	157,2	3	76,2	1,62	41,5	8
6"	111	19	482,6	14,5	368,3	8,5	215,9	4,25	108,0	2,12	54,0	8
8"	146	21,75	552,5	17,25	438,2	10,62	269,7	5	127,0	2,12	54,0	12
10"	184	26,5	673,1	21,25	539,8	12,75	323,9	6,5	165,1	2,62	66,5	12
12"	219	30	762,0	24,38	619,3	15	381,0	7,25	184,2	2,88	73,0	12

FLANGE STANDARDS

- According to ASME B16.5
- According to ASME B16.47 Serie A (MSS SP-44)
- According to ASME B16.47 Serie B (API 605)

BUTTWELDING END DIMENSIONS ACCORDING TO ASME B16.25

Welding End Detail for Joint Without Backing Ring

WELD BEVEL DETAIL FOR WALL THICKNESS NOT OVER 22mm. (0,88in.)

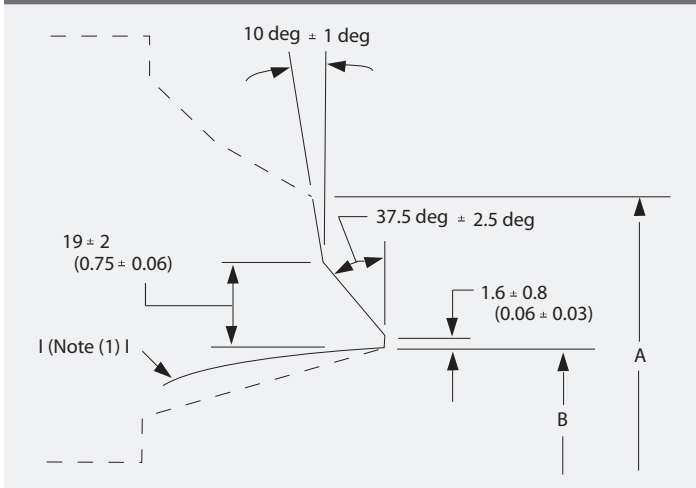

WELD BEVEL DETAIL FOR WALL THICKNESS OVER 22mm. (0,88in.)

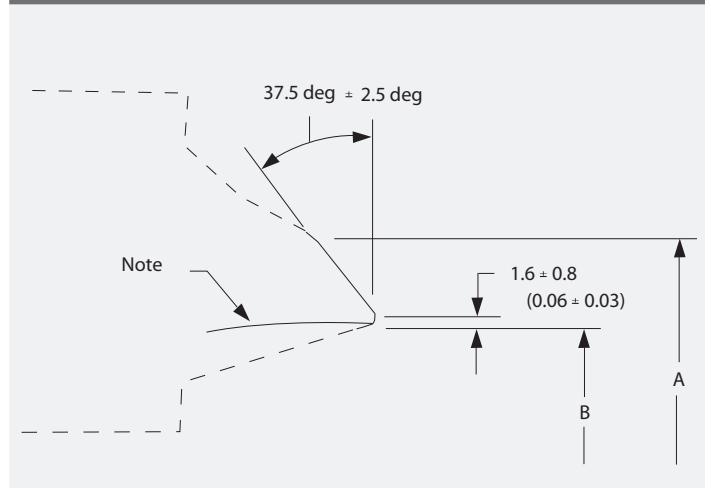

Note : Internal surface may be as-formed or machined for dimension B at root face. Contour within the envelope is manufacturer's option, unless otherwise specifically purchase order for.

Nominal Pipe Size (NPS)	A		B												
			10		20		30		STD		XS		40		
	inch.	mm.	inch.	mm.	inch.	mm.	inch.	mm.	inch.	mm.	inch.	mm.	inch.	mm.	
3" (80)	3,59	91,2												3,068	77,9
4" (100)	4,62	117,3												4,026	102,3
6" (150)	6,78	172,2												6,065	154,1
8" (200)	8,78	223,0												7,981	202,7
10" (250)	10,94	277,9												10,020	254,5
12" (300)	12,97	329,4								12,000	304,8	11,750	298,5	11,938	303,2
14" (350)	14,25	362,0								13,250	336,6	13,000	330,2	13,124	333,3
16" (400)	16,25	412,8								15,250	387,4			15,000	381,0
18" (450)	18,28	464,3								17,250	438,2	17,000	431,8	16,876	428,7
20" (500)	20,31	515,9								19,250	489,0	19,000	482,6	18,812	477,8
24" (600)	24,38	619,3						22,876	581,1	23,250	590,6	23,000	584,2	22,624	574,6
30" (750)	30,38	771,7	29,376	746,2	29,000	736,6	28,750	730,3							
36" (900)	36,50	927,1	35,376	898,6	35,000	889,0	34,750	882,7						34,500	876,3

Nominal Pipe Size (NPS)	B													
	60		80		100		120		140		160		XXS	
	inch.	mm.	inch.	mm.	inch.	mm.	inch.	mm.	inch.	mm.	inch.	mm.	inch.	mm.
3" (80)			2,900	73,7							2,624	66,6	2,300	58,4
4" (100)			3,826	97,2			3,624	92,0			3,438	87,3	3,152	80,1
6" (150)			5,761	146,3			5,501	139,7			5,187	131,7	4,897	124,4
8" (200)	7,813	198,5	7,625	193,7	7,437	188,9	7,187	182,5	7,001	177,8	6,813	173,1	6,875	174,6
10" (250)	9,750	247,7	9,562	242,9	9,312	236,5	9,062	230,2	8,750	222,3	8,500	215,9		
12" (300)	11,626	295,3	11,374	288,9	11,062	281,0	10,750	273,1	10,500	266,7	10,126	257,2		
14" (350)	12,812	325,4	12,500	317,5	12,124	307,9	11,812	300,0	11,500	292,1	11,188	284,2		
16" (400)	14,688	373,1	14,312	363,5	13,938	354,0	13,562	344,5	13,124	333,3	12,812	325,4		
18" (450)	16,500	419,1	16,124	409,5	15,688	398,5	15,250	387,4	14,876	377,9	14,438	366,7		
20" (500)	18,376	466,8	17,938	455,6	17,438	442,9	17,000	431,8	16,500	419,1	16,062	408,0		
24" (600)	22,062	560,4	21,562	547,7	20,938	531,8	20,376	517,6	19,876	504,9	19,312	490,5		

PRESSURE TEMPERATURE RATINGS

PRESSURE TEMPERATURE RATINGS FOR ALLOY STEEL ASTM A217 C5 (According to ASME B16.34)

TEMPERATURE		WORKING PRESSURE - STANDARD CLASS VALVES																	
°F	°C	150	PN20		300	PN50		600	PN100		900	PN150		1500	PN250		2500	PN420	
		PSig	Kg/cm ²	Bar	PSig	Kg/cm ²	Bar	PSig	Kg/cm ²	Bar	PSig	Kg/cm ²	Bar	PSig	Kg/cm ²	Bar	PSig	Kg/cm ²	Bar
-20 to 100	-29 to 38	290	20,4	20,0	750	52,7	51,7	1500	105,5	103,4	2250	158,2	155,0	3750	263,6	258,4	6250	439,4	430,6
200	95	260	18,3	17,9	745	52,4	51,3	1490	104,7	102,7	2235	157,1	154,0	3725	261,9	256,7	6205	436,2	427,5
300	150	230	16,2	15,8	715	50,3	49,3	1430	100,5	98,5	2150	151,1	148,1	3580	251,7	246,7	5965	419,3	411,0
400	205	200	14,1	13,8	705	49,6	48,6	1410	99,1	97,1	2115	148,7	145,7	3530	248,2	243,2	5880	413,4	405,1
500	260	170	12,0	11,7	665	46,7	45,8	1330	93,5	91,6	1995	140,2	137,5	3325	233,7	229,1	5540	389,5	381,7
600	315	140	9,8	9,6	605	42,5	41,7	1210	85,1	83,4	1815	127,6	125,1	3025	212,7	208,4	5040	354,3	347,3
650	345	125	8,8	8,6	590	41,5	40,7	1175	82,6	81,0	1765	124,1	121,6	2940	206,7	202,6	4905	344,8	338,0
700	375	110	7,7	7,6	570	40,1	39,3	1135	79,8	78,2	1705	119,9	117,5	2840	199,7	195,7	4730	332,5	325,9
750	400	95	6,7	6,5	530	37,3	36,5	1055	74,2	72,7	1585	111,4	109,2	2640	185,6	181,9	4400	309,3	303,2
800	425	80	5,6	5,5	510	35,9	35,1	1015	71,4	69,9	1525	107,2	105,1	2540	178,6	175,0	4230	297,4	291,4
850	450	65	4,6	4,5	485	34,1	33,4	965	67,8	66,5	1450	101,9	99,9	2415	169,8	166,4	4030	283,3	277,7
900	485	50	3,5	3,4	370	26,0	25,5	740	52,0	51,0	1110	78,0	76,5	1850	130,1	127,5	3085	216,9	212,6
950	510	35	2,5	2,4	275	19,3	18,9	550	38,7	37,9	825	58,0	56,8	1370	96,3	94,4	2285	160,6	157,4
1000	540	20	1,4	1,4	200	14,1	13,8	400	28,1	27,6	595	41,8	41,0	995	69,9	68,6	1655	116,3	114,0
1050	565	20	1,4	1,4	145	10,2	10,0	290	20,4	20,0	430	30,2	29,6	720	50,6	49,6	1200	84,4	82,7
1100	595	20	1,4	1,4	100	7,0	6,9	200	14,1	13,8	300	21,1	20,7	495	34,8	34,1	830	58,3	57,2
1150	620	20	1,4	1,4	60	4,2	4,1	125	8,8	8,6	185	13,0	12,7	310	21,8	21,4	515	36,2	35,5
1200	650	20	1,4	1,4	35	2,5	2,4	70	4,9	4,8	105	7,4	7,2	170	12,0	11,7	285	20,0	19,6

TEMPERATURE		WORKING PRESSURE - SPECIAL CLASS VALVES																	
°F	°C	150	PN20		300	PN50		600	PN100		900	PN150		1500	PN250		2500	PN420	
		PSig	Kg/cm ²	Bar	PSig	Kg/cm ²	Bar	PSig	Kg/cm ²	Bar	PSig	Kg/cm ²	Bar	PSig	Kg/cm ²	Bar	PSig	Kg/cm ²	Bar
-20 to 100	-29 to 38	290	20,4	20,0	750	52,7	51,7	1500	105,5	103,4	2250	158,2	155,0	3750	263,6	258,4	6250	439,4	430,6
200	95	290	20,4	20,0	750	52,7	51,7	1500	105,5	103,4	2250	158,2	155,0	3750	263,6	258,4	6250	439,4	430,6
300	150	280	19,7	19,3	730	51,3	50,3	1455	102,3	100,2	2185	153,6	150,5	3645	256,2	251,1	6070	426,7	418,2
400	205	275	19,3	18,9	720	50,6	49,6	1440	101,2	99,2	2160	151,8	148,8	3600	253,1	248,0	6000	421,8	413,4
500	260	275	19,3	18,9	720	50,6	49,6	1440	101,2	99,2	2160	151,8	148,8	3600	253,1	248,0	6000	421,8	413,4
600	315	270	19,0	18,6	705	49,6	48,6	1415	99,5	97,5	2120	149,0	146,1	3535	248,5	243,6	5895	414,4	406,2
650	345	270	19,0	18,6	700	49,2	48,2	1395	98,1	96,1	2095	147,3	144,3	3495	245,7	240,8	5820	409,1	401,0
700	375	265	18,6	18,3	685	48,2	47,2	1370	96,3	94,4	2055	144,5	141,6	3430	241,1	236,3	5715	401,8	393,8
750	400	255	17,9	17,6	660	46,4	45,5	1320	92,8	90,9	1980	139,2	136,4	3300	232,0	227,4	5500	386,7	379,0
800	425	245	17,2	16,9	640	45,0	44,1	1275	89,6	87,8	1915	134,6	131,9	3195	224,6	220,1	5320	374,0	366,5
850	450	230	16,2	15,8	605	42,5	41,7	1210	85,1	83,4	1815	127,6	125,1	3020	212,3	208,1	5035	354,0	346,9
900	485	175	12,3	12,1	465	32,7	32,0	925	65,0	63,7	1390	97,7	95,8	2315	162,7	159,5	3855	271,0	265,6
950	510	130	9,1	9,0	345	24,3	23,8	685	48,2	47,2	1030	72,4	71,0	1715	120,6	118,2	2855	200,7	196,7
1000	540	95	6,7	6,5	250	17,6	17,2	495	34,8	34,1	745	52,4	51,3	1245	87,5	85,8	2070	145,5	142,6
1050	565	70	4,9	4,8	180	12,7	12,4	360	25,3	24,8	540	38,0	37,2	900	63,3	62,0	1500	105,5	103,4
1100	595	50	3,5	3,4	125	8,8	8,6	250	17,6	17,2	375	26,4	25,8	620	43,6	42,7	1035	72,8	71,3
1150	620	30	2,1	2,1	75	5,3	5,2	155	10,9	10,7	230	16,2	15,8	385	27,1	26,5	645	45,3	44,4
1200	650	15	1,1	1,0	45	3,2	3,1	85	6,0	5,9	130	9,1	9,0	215	15,1	14,8	355	25,0	24,5

■ For welding end valves only. Flanged end ratings terminate at 1000°F.

ASTM MATERIAL LIST

VALVE MATERIALS SELECTION

VALVE TYPE	TYPE	CLASS	END CONNECTION	MATERIAL		OPERATION
				SHELL	TRIM	
GATE VALVE	BOLTED BONNET	150	FLAT FACE	ASTM A216 WCB	F6 a	HANDWHEEL
		300		ASTM A216 WCC		
	600	ASTM A352 LCB		304 & 304L		
	900	ASTM A352 LCC				
1500	ASTM A352 LC1	316 & 316L				
2500	ASTM A352 LC2					
GLOBE VALVE	BOLTED BONNET	900	RAISED FACE	ASTM A352 LC3	321	BEVEL GEAR
		1500		ASTM A217 WC1		
	2500	ASTM A217 WC6		347		
		ASTM A217 WC9				
GLOBE VALVE	PRESSURE SEAL	900	RING JOINT	ASTM A217 C5	F55	ELECTRIC
		1500		ASTM A217 C12		
	2500	ASTM A351 CF3		BRONZE		
		ASTM A351 CF3M				
SWING CHECK VALVE	BOLTED COVER	150	BUTTWELDED ENDS	ASTM A351 CF8	MONEL	HYDRAULIC
		300		ASTM A351 CF8M		
	600	ASTM A351 CF8C		HASTELLOY		
	900	ASTM A351 CD4MCu				
1500	ASTM A351 CKMCuN	STELLITE				
2500	ASTM A351 CN7M					

ASTM MATERIALS LIST

ASTM Material	Chemical Requirements											Mechanical Requirements			
	C Max.	Mn Max.	P Max.	S Max.	Si Max.	Cr Max.	Ni Max.	Mo Max.	Cu Max.	V Max.	Other Max.	T.E. Kg/mm ²	Y.S. Min. Kg/mm ²	E % Min.	R.A. % Min.
A216 WCB	0.30	1.00	0.04	0.045	0.60	0.50	0.50	0.20	0.30	0.03		49.2/66.8	25.3	22	35
A352 LCB	0.30	1.00	0.04	0.045	0.60	0.50	0.50	0.20	0.30	0.03		45.9/63.2	24.5	24	35
A217 C5	0.20	0.40/0.70	0.04	0.045	0.75	4.00/6.50	0.50	0.45/0.65	0.5		W: 0.10	63.2/81.1	42.3	18	35
A351 CF8M	0.08	1.50	0.040	0.040	1.50	18/21	9/12	2/3				49.5 min.	20.9	30	-
A217 CA15	0.15	1.00	0.04	0.040	1.50	11.5/14.0	1.00	0.50				63.3 min.	45.7	18	30
A105	0.35	0.60/1.05	0.035	0.040	0.10/0.35	0.30	0.40	0.12	0.40	0.05	Cb: 0.02	49.2 min.	25.3	22	30
A182 F6a	0.15	1.00	0.040	0.030	1.00	11.5/13.5	0.50					59.7	38.7	18	35
A182 F304	0.08	2.00	0.045	0.030	1.00	18.0/20.0	8.0/11.0				N: 0.10	52.5	20.9	30	50
A182 F304L	0.030	2.00	0.045	0.030	1.00	18.0/20.0	8.0/13.0				N: 0.10	49.5	17.3	30	50
A182 F316	0.08	2.00	0.045	0.030	1.00	16.0/18.0	10.0/14.0	2.00/3.00			N: 0.10	52.5	20.9	30	50
A182 F316L	0.030	2.00	0.045	0.030	1.00	16.0/18.0	10.0/15.0	2.00/3.00			N: 0.10	49.5	17.3	30	50
A182 F321	0.08	2.00	0.045	0.030	1.00	17/19	9.0/12.0				Ti ≥ 5C ≤ 0.70%	52.5	20.9	30	50
A182 F347	0.08	2.00	0.045	0.030	1.00	17.0/20.0	9.0/13.0				Cb+Ta 10xCmin	52.5	20.9	30	50
A193 B7	0.37/0.49	0.65/1.10	0.035	0.040	0.15/0.35	0.75/1.20		0.15/0.25				87.9/70.3	73.8/52.7	16/18	50
A194 2H	0.40 min.	1.00	0.040	0.050	0.40										
A439 D2 (Ni-Resist)	2.9	1.80/2.40	0.080		1.00/3.00	0.5	21.00/24.00					40.7	19.7	20	-
B148 Gr. B (Al. Bronze)									86.0 min.		Al: 9.0/11.0 Fe: 0.80/1.5	52.2 min.	28.1	12	-
AWS A5.13 CoCrA (Stellite)	0.70/1.40	2.00			2.00	25.0/32.0	3.0	1.00			W: 3.00/6.00 Fe: 5.0 Co: Remainder	105/162	45	53.4	5/8

CV FLOW COEFFICIENTS

	CLASS	150	300	600	900		1500		2500	
	SIZE	BB	BB	BB	BB	PS	BB	PS	BB	PS
GATE	2"	250	250	250	230	225	230	225	160	170
	3"	620	620	620	580	480	520	480	370	400
	4"	1160	1160	1160	1050	750	930	750	630	570
	6"	2700	2700	2700	2550	1850	2250	1700	1500	1550
	8"	5100	5100	5100	4400	4300	3800	3000	2650	2400
	10"	8050	8050	7800	7050	5450	6050	4750	4500	400
	12"	12050	12050	11500	10000	7450	9100	6500	6000	5900
	14"	15100	15100	14000	13100	9500	11500	8500	7050	
	16"	20300	20300	18500	18200	11900	15100	10200		
	18"	26100	25000	23000	21500	14500		13500		
	20"	33500	32500	28500	26500	18500				
	24"	50000	48500	43000						
	30"	79000								
	36"	115500								
GLOBE	2"	55	55	55	45	45	40	40	25	25
	3"	105	105	105	90	90	85	80	65	60
	4"	190	190	190	150	145	120	120	100	90
	6"	425	425	425	400	380	360	350	245	240
	8"	790	790	790	700	650	600	550	400	350
	10"	1250	1250	1200		850		700		500
	12"	1900	1900	1850		1000		950		850
	16"	3300				2100		1600		
SWING CHECK	2"	125	125	125	100	100	100	100	60	60
	3"	280	280	280	240	240	220	220	150	150
	4"	490	490	490	460	490	400	400	250	200
	6"	1150	1150	1150	1100	850	1050	800	600	450
	8"	2250	2250	2200	2000	1500	1650	1200	1050	850
	10"	3400	3400	3300		2200		1900		1600
	12"	4900	4900	4800		2900		2300		2050
	14"	6100	6100	5850		3700		3500		
	16"	8700	8700	8100		6950		4700		
	18"	11900	11550							
	20"	14800	14000							
	24"	21000								
30"	31000									
36"	52000									

TEST

SHELL, BACKSEAT & CLOSURE TEST PRESSURE in Kg/cm² (psig) STANDARD API 598/ISO 5208 (STANDARD CLASS)

Test of... ASTM Materials	CLASS 150		CLASS 300		CLASS 600		CLASS 900		CLASS 1500		CLASS 2500	
	Shell	High-pressure Closure*	Shell	High-pressure Closure*	Shell	High-pressure Closure*	Shell	High-pressure Closure*	Shell	High-pressure Closure*	Shell	High-pressure Closure*
		Backseat		Backseat		Backseat		Backseat		Backseat		Backseat
WCB	32	23	79	58	157	116	236	172	392	287	652	478
LF2,A105	(450)	(315)	(1125)	(815)	(2225)	(1650)	(3350)	(2445)	(5575)	(4080)	(9275)	(6800)
WC1	28	21	74	55	148	109	221	162	367	269	612	448
LC1-LCB	(400)	(300)	(1050)	(775)	(2100)	(1550)	(3150)	(2300)	(5225)	(3825)	(8700)	(6375)
WCC,F11cl.2												
WC4,F5												
WC5,F9												
WC6,C12A												
WC9-C5	32	23	79	58	158	116	237	174	396	290	659	483
C12-LCC	(450)	(315)	(1125)	(815)	(2250)	(1650)	(3375)	(2475)	(5625)	(4125)	(9375)	(6875)
LC2-LC3												
CK3MCuN												
CD4MCu												
CF3-CF8												
CF8C,F304												
CF8M,F316	30	23	77	56	153	113	229	167	380	280	633	464
CF3M,F347	(425)	(315)	(1100)	(800)	(2175)	(1600)	(3250)	(2375)	(5400)	(3975)	(9000)	(6600)
CF3A,CF8A												
CN7M	25	20	63	48	127	93	190	141	317	232	528	387
	(345)	(275)	(900)	(675)	(1800)	(1325)	(2700)	(2000)	(4500)	(3300)	(7500)	(5500)

* LOW-PRESSURE CLOSURE (Air) 4,2 – 7kg/cm2 (70-100psig).
Other standards as EN 17266 , API 6D y MSS SP-61, could be used at costumer request.

NOTES

.....

.....

.....

.....

.....

.....

.....

.....

.....

.....

.....

.....

JC VALVES

The quality option

MORE PRODUCTS

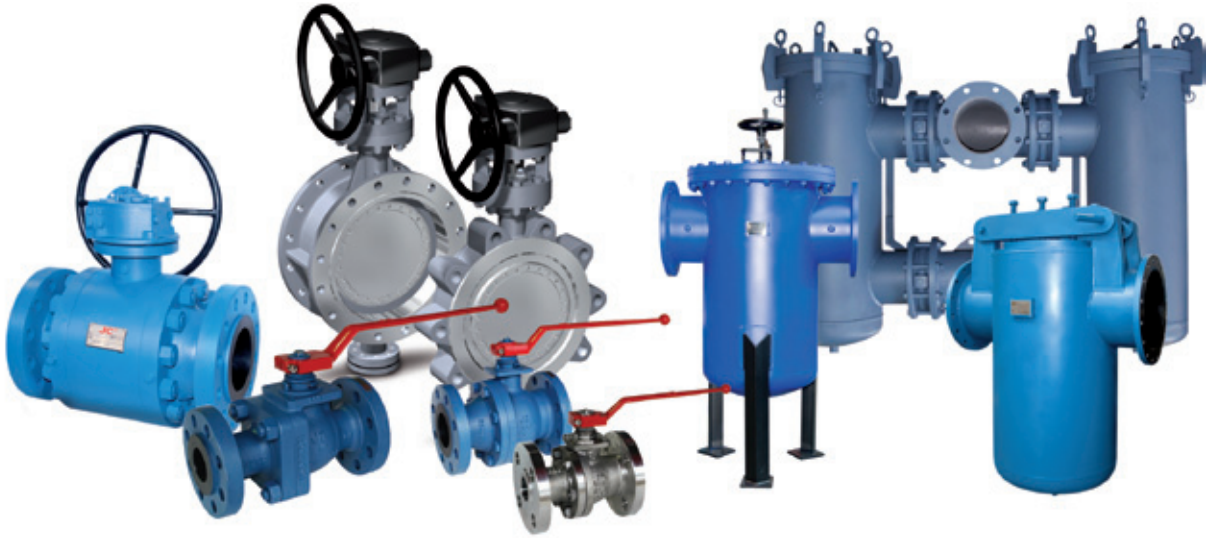

BALL VALVES - TRIPLE OFFSET BUTTERFLY VALVES - STRAINERS

ACCESSORIES



CHAIN WHEELS - GEAR OPERATORS - ELECTRIC ACTUATOR - POSITION INDICATOR
LOCKING DEVICES - LANTERN RING - LIMIT SWITCH - BYPASS - DAMPER

GATE, GLOBE & CHECK VALVES

JC FÁBRICA DE VÁLVULAS S.A.

C/ Cantabria, 2 - Polígono Industrial Les Salines
08830 Sant Boi del Llobregat
Barcelona (Spain)
Tél. +34 93 654 86 86
Fax +34 93 654 86 87

sales@jc-valves.com
www.jc-valves.com



Edition 02/2013

