

| BALL VALVES |

# METAL SEATED

½" - 24" | Class 150 - Class 1500  
DN 15 - DN 300 | PN 16 - PN 40

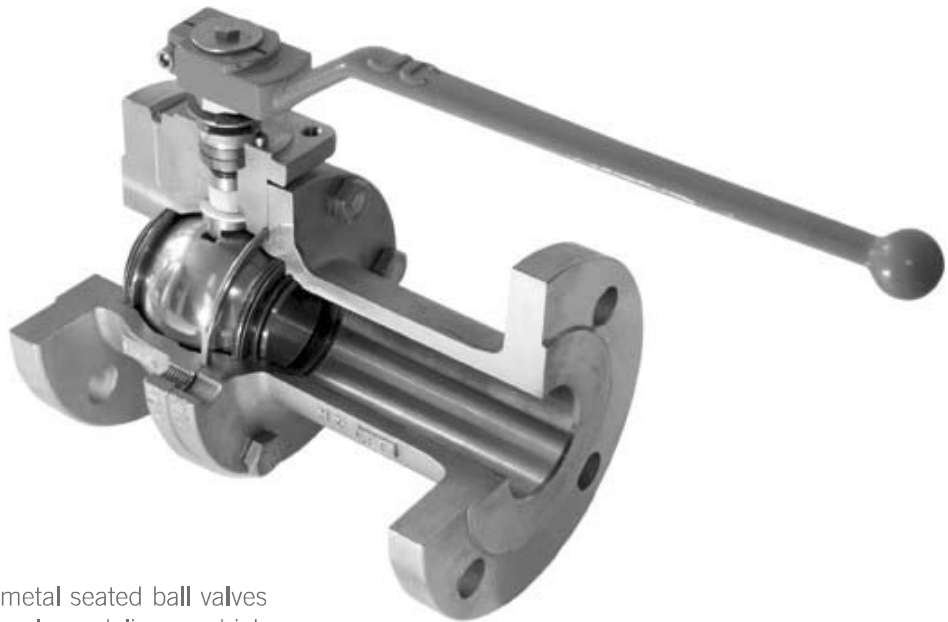

JC offers also a large range of metal seated ball valves for different services (slurries, pulp and liquors, high temperature, abrasive or sticking fluids, control).

- » **Bubble tight sealing up to 327 °C and Class V up to 500 °C**
- » **Low coefficient of friction**
- » **Excellent sliding and running properties**
- » **Hardens the complete surface of ball and seats**

## WHY METAL SEATED BALL VALVES?

METAL SEATED BALL VALVES ARE MAINLY USED FOR HEAVY DUTY APPLICATIONS SUCH AS:

- » **High temperatures: above 260 °C** the use of soft seats is not recommended.
- » **Abrasive media: even small particles can damage soft seats.**
- » **High Velocity in opening/closing cycles: this action can perfectly deform the soft ring and destroy the seat.**

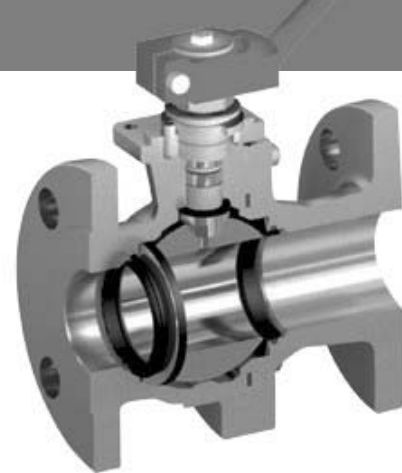

## HARDENING TREATMENTS

### HT-65

Max. Temperature: 500 °C  
 Corrosion Resistance: Medium  
 Abrasion Resistance: Medium

This is an exclusive treatment developed by JC with two main advantages, first all the ball and seat surface is hardened and second there is no additional overlay on the seat surface. This gives a very good tightness and a lower torque. The surface is hardened to 70 Rockwell C and it is valid to work upto 500 °C.



### CT-70

Max. Temperature: 550 °C  
 Corrosion Resistance: Medium  
 Abrasion Resistance: High

Is a Tungsten Carbide coating in a metallic matrix bonded. Mechanically to the base material by HVOF methods. This treatment gives a very good resistance to abrasion and impact and is suitable to work upon 550 °C.



### CC-60

Max. Temperature: 800 °C  
 Corrosion Resistance: High  
 Abrasion Resistance: High

Is a Chromium Carbide coating in a nickel-chrome base in a metallic matrix bonded mechanically to the base material by HVOF methods. This treatment gives a very good resistance to abrasion and is the best choice for severe corrosion applications. It is suitable to work up to 800 °C.



## DIFFERENT SEAT DESIGNS

Metallic Seat  
with O'ring

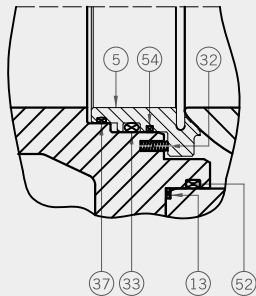

- ⑤ Seat
- ③② Helicol spring
- ③③ ③⑦ O'rings
- ⑬ ⑤④ Graphite gasket
- ⑤② O'ring

Metallic Seat  
with Graphite

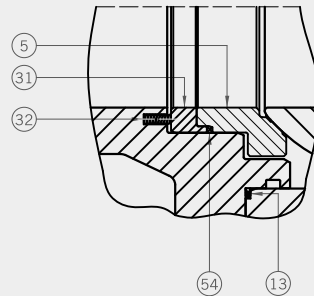

- ⑤ Seat
- ⑬ Spiralwound
- ③① Seat carrier
- ③② Helicol spring
- ⑤④ Graphite gasket

Metallic Seat  
for Floating Valves

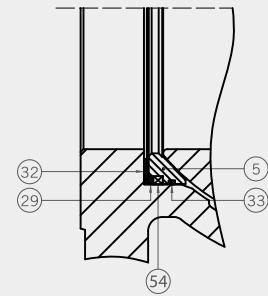

- ⑤ Seat
- ②⑨ Washer
- ③③ O'ring
- ③② Belleville spring
- ⑤④ Graphite gasket

## RANGE OF METAL SEATED BALL VALVES

JC can produce the following metal seated ball valves:

Pressure Class	Floating	Monoblock	Trunnion
150	1/2" upto 8"	-	2" upto 24"
300	1/2" upto 4"	-	2" upto 24"
600	1/2" upto 2"	-	2" upto 24"
800	-	1/2" upto 2"	-
900	-	-	2" upto 12"
1500	-	1/2" upto 2"	2" upto 8"

## PRODUCTION OF METAL SEATED BALL VALVES

Metal seated ball valves are mainly used for heavy duty applications.

One of the main advantages of using JC metal seated ball valves is the fact that we can transform a soft seated stock valves into a metal seated valve.

### THE STEPS TO BE DONE ARE:

- » Re-machining of the body.
- » Lapping of the ball and seats.
- » Hardening treatment to ball and seats.
- » Final adjustment of the ball with its seats.
- » Assembly and test.



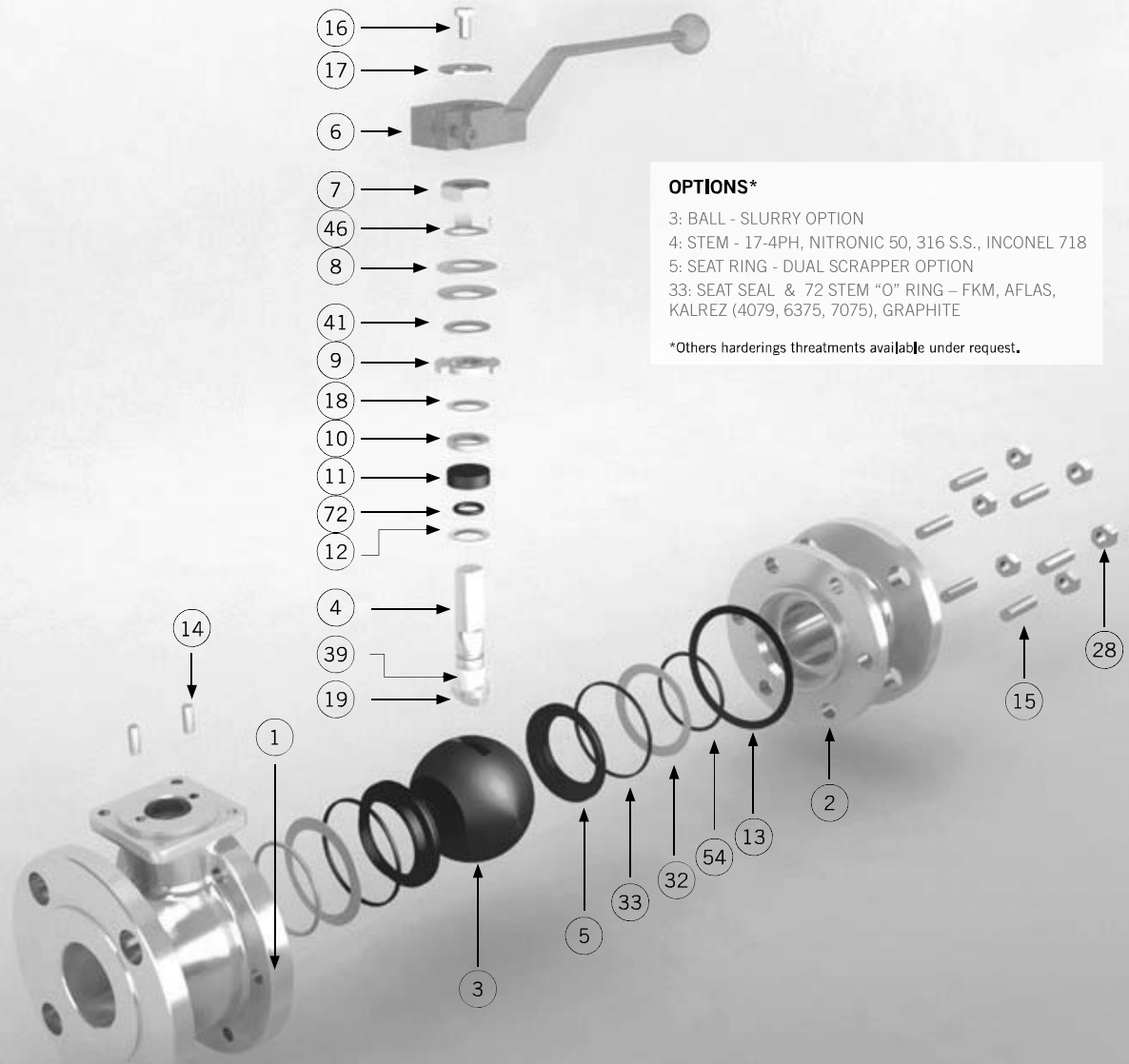

**OPTIONS\***

- 3: BALL - SLURRY OPTION
- 4: STEM - 17-4PH, NITRONIC 50, 316 S.S., INCONEL 718
- 5: SEAT RING - DUAL SCRAPER OPTION
- 33: SEAT SEAL & 72 STEM "O" RING – FKM, AFLAS, KALREZ (4079, 6375, 7075), GRAPHITE

\*Others hardenings threadments available under request.

# Materials

## EN-DIN

## ASME

Item	Description	EN-DIN		ASME	
		3516 AIM 3540 AIM	3516 IIM 3540 IIM	3515 AIM 3530 AIM	3515 IIM 3530 IIM
		Material		Material	
1	Body	1.0619	1.4408	A216 Gr.WCB (C≤0,25%)	A351 Gr. CF8M
2	Body connector	1.0619	1.4408	A216 Gr.WCB (C≤0,25%)	A351 Gr. CF8M
3	Ball	316 S.S. + HT70		316 S.S. + HT70	
4	Stem	See options		See options	
5	Seat ring	316 S.S. + HT70		316 S.S. + HT70	
6	Wrench	Nodular Iron		Nodular Iron	
7	Gland nut	Zinc plated carbon steel	AISI 303	Zinc plated carbon steel	AISI 303
8	Disk spring	Carbon steel	ENP Carbon Steel	Carbon steel	ENP Carbon Steel
9	Stop plate	Carbon steel	AISI 304	Carbon steel	AISI 304
10	Gland	AISI 303	AISI 316	AISI 303	AISI 316
11	Gland packing	Graphite		Graphite	
12	Stem thrust seal	316 S.S. + HT-65		316 S.S. + HT-65	
13	Body connector seal	AISI 316L +Graphite		AISI 316L + Graphite	
14	Stop pin	Carbon St.	Stainless St.	Carbon St.	Stainless St.
15	Stud (DN 32 to DN 100)	A4-70		A193Gr. B7M Zinc dichromate	A193 Gr. B8M
15.1	Bolt	A4-70		-	-
16	Bolt	DIN 933 A4-70		DIN 933 A4-70	
17	Washer	Zinc plated carbon steel	AISI 304	Zinc plated carbon steel	AISI 304
18	Thrust washer	316 S.S. + HT65		316 S.S. + HT65	
19	Antistatic device	Stainless St.		Stainless St.	
28	Nut (DN 32 to DN 100)	A4-70		A194 Gr. 2HM Zinc dichromate	A194 Gr. 8M
32	Seat disk spring	Inconel X-750		Inconel X-750	
33	Seat Ring	See options		See options	
39	Stem bushing	25% G.F. PTFE		25% G.F. PTFE	
41	Spacer (DN 40 to DN200)	Carbon steel	AISI 304	Carbon steel	AISI 304
46	Locking washer	AISI 304		AISI 304	
54	Seat Seal	Graphite		Graphite	
72	Stem "O" Ring	See options		See options	

EN-DIN 3516 / 3540

PN 16 / 40

Full Bore

PN 16. From DN 65 to DN 200

PN 40. From DN 15 to DN 150

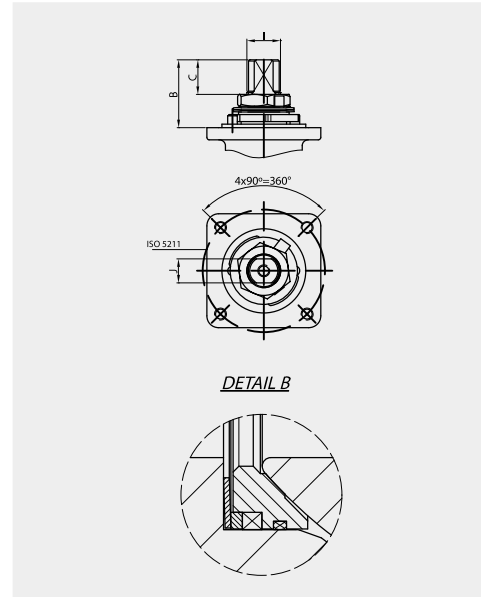
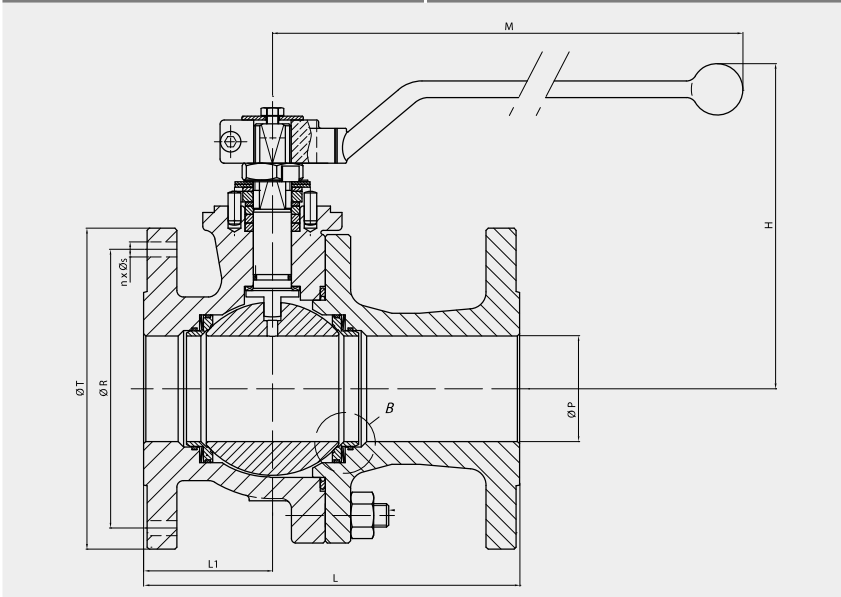

Pressure - Temperature

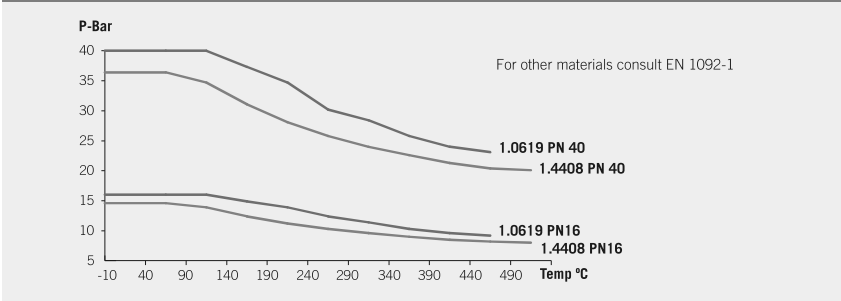

(\*) Dimensions of diameters of drills ISO 5211 refer to table from page 60.



Fig. 3516 (PN 16)

DN	ØP	L	L1	ØR	n x ØS	ØT	H	M	ISO 5211	B	C	I	J	WEIGHT 3516	WEIGHT 3316	TORQUE	Kv
65	65	170	76	145	4x18	185	169	348	F07	44	19,7	M22x1.5	16	16	18,3	180	550
80	80	180	82	160	8x18	200	207	445	F10	44,5	19,7	M25x1.5	18	22	25	250	1000
100	100	190	90	180	8x18	220	231	495	F10	56,5	29,2	M28x1.5	20	32	36	390	1650
125	125	325	120	210	8x18	250	262	698	F12	56	27,6	M35x2	25	52,5	-	500	3000
150	151	350	135	240	8x22	285	298	698	F12	68	38,5	M40x1.5	29	76	-	800	4200
200	203	400	200	295	12x22	340	352	868	F14	72	39	M45x2	32	111	-	1200	9000

Fig. 3540 (PN 40)

DN	ØP	L	L1	ØR	n x ØS	ØT	H	M	ISO 5211	B	C	I	J	WEIGHT 3540	WEIGHT 3340	TORQUE	Kv
15	15	115	53	65	4x14	95	110	164	F05	11,2	5,7	M12x1.5	9	2,8	3	26	20
20	20	120	52	75	4x14	105	117	164	F05	13,2	9,2	M12x1.5	9	3,6	-	35	40
25	25	125	49	85	4x14	115	129	164	F05	22,7	10,2	M12x1.5	9	5	5,2	40	75
32	32	130	54	100	4x18	140	131	210	F05	32	13,7	M16x1.5	12	7	7,6	60	130
40	40	140	55	110	4x18	150	148	213	F07	41,5	19,2	M18x1.5	13	9	9,6	90	170
50	50	150	61	125	4x18	165	155	213	F07	41,5	19,2	M18x1.5	13	12	12,9	120	270
65	65	170	76	145	8x18	185	169	348	F07	44	19,7	M22x1.5	16	17	-	160	550
80	80	180	75	160	8x18	200	207	445	F10	44,5	19,7	M25x1.5	18	23	-	254	1000
100	100	190	91	190	8x22	235	231	495	F10	56,5	29,2	M28x1.5	20	35	-	-	1650
125	125	325	120	220	8x26	270	262	698	F12	56	27,6	M35x2	25	57	-	-	3000
150	151	350	135	250	8x26	300	298	698	F12	68	38,5	M40x1.5	29	83,5	-	-	4200

(\*) Dimensions in mm and weight in kg.  
(\*\*) Weights and dimensions can be changed without notice.



| BALL VALVES |

# METAL SEATED UDV

1/2" - 2" | Class 800 - Class 1500

The Ultimate Drain Valve (UDV) it is a high temperature special design. The valve has got a monobloc welded body and it is reduced bore. This valve is designed to support high temperatures at high pressures.

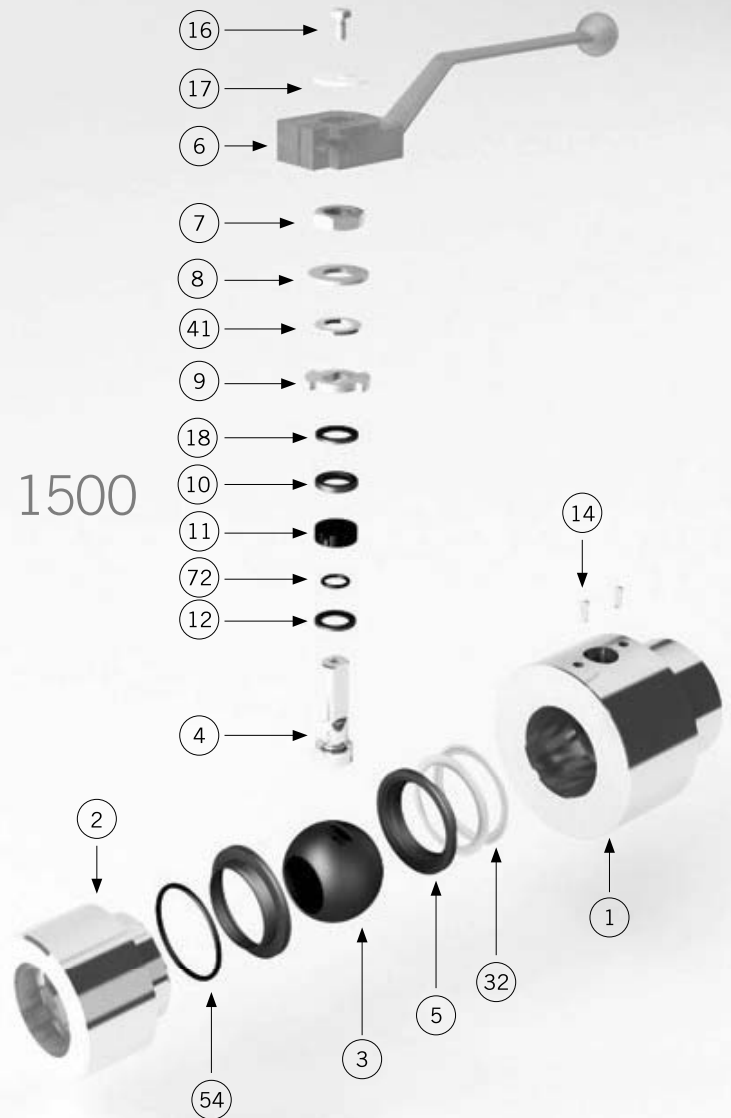

## Materials

### METAL SEATED UDV

Item	Description	C.S. BODY	S.S. BODY
1	Body	A 105	A 479 Type 316
2	Body connector	A 105	A 479 Type 316
3	Ball	AISI 316 + HT-65 (*)	
4	Stem	17-4 PH + HT-65 (*)	
5	Metallic seat	AISI 316 + HT-65	
6	Wrench	GGG-40	
7	Gland nut	Zinc plated carbon st.	AISI 303
8	Disk spring	Carbon St.	E.N.P. Carbon St.
9	Stop plate	Carbon St.	AISI 304
10	Gland	AISI 316 + HT-65	
11	Gland packing	Graphite	
12	Stem thrust seal	AISI 316 + HT-65	
14	Stop pin	Carbon St.	Stainless St.
16	Bolt	DIN 933 5.6 Zinc plated	DIN 933 A2
17	Washer	Carbon St.	Stainless St.
18	Thrust washer	AISI 316 + HT-65	
32	Disk spring	Inconel 718	
41	Spacer	Carbon St.	Stainless St.
54	Seat gasket	Graphite	
72	O'ring	AFlas	

(\*) Other materials under request.

**UDV CLASS 800 & 1500 AIM & IIM TYPE**

**Class 800 / 1500**

**Reduced Bore**

Class 800. From ½" to 2"

Class 1500. From ½" to 2"

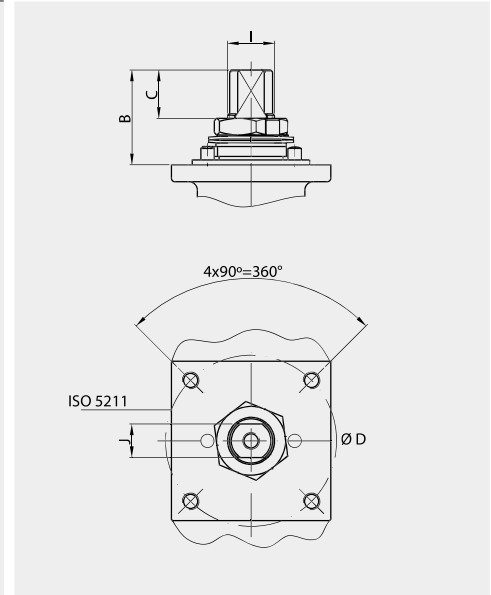
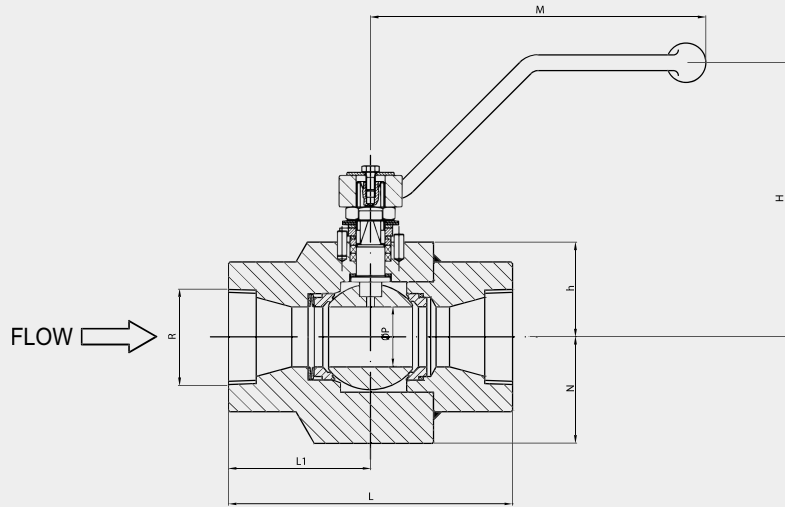

(\*) Diameter of drills ISO 5211 = n x F.

**Pressure - Temperature**

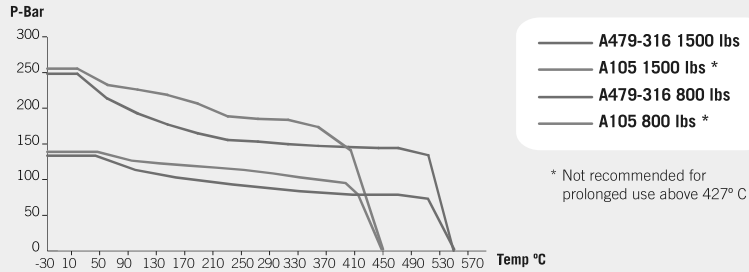

**Fig. UDV (Class 800)**

DN	ØP	L	L1	R	N	h	H	M	ISO 5211	B	C	ØD	n x F	I	J	WEIGHT	TORQUE	Kv
½"	15	90	45	NPT	37,5	32	102	164	F04	18,4	7,8	42	4 x M5	M12 x1,5	9	3,5	30	11
¾"	15	110	55	NPT	37,5	32	102	164	F04	18,4	7,8	42	4 x M5	M12 x1,5	9	4,5	30	11
1"	20	120	60	NPT	42,5	35,5	106	164	F05	20	8,5	50	4 x M6	M12 x1,5	9	5	37	14
1½"	28	150	75	NPT	60	50	111	210	F05	31,5	15,5	50	4 x M6	M16 x1,5	12	6	102	30
2"	36	180	90	NPT	67,5	60	128	213	F07	38,5	19	70	4 x M8	M18 x1,5	13	10	173	72

**Fig. UDV (Class 1500)**

DN	ØP	L	L1	R	N	h	H	M	ISO 5211	B	C	ØD	n x F	I	J	WEIGHT	TORQUE	Kv
½"	15	90	45	NPT	37,5	32	102	164	F04	18,4	7,8	42	4 x M5	M12x1,5	9	3,5	39	11
¾"	15	110	55	NPT	37,5	32	102	164	F04	18,4	7,8	42	4 x M5	M12x1,5	9	4,5	39	11
1"	20	120	60	NPT	42,5	35,5	106	164	F05	20	8,5	50	4 x M6	M12x1,5	9	5	54	14
1½"	28	150	75	NPT	60	50	111	210	F05	31,5	15,5	50	4 x M6	M16x1,5	12	6	161	30
2"	36	180	90	NPT	67,5	60	128	213	F07	38,5	19	70	4 x M8	M18x1,5	13	10	287	72

(\*) Dimensions in mm and weight in kg.  
(\*\*) Weights and dimensions can be changed without notice.